

# Savannah Design Review Guidelines Savannah, Tennessee 2016 (Rev. 2019)

## Historic Zoning Commission City of Savannah, Tennessee



## **ACKNOWLEDGMENTS**

The Savannah Design Review Guidelines manual was prepared in association with the Savannah Historic Zoning Commission. Thanks are due to Seth Sumner, Assistant City Manager for his project coordination. We also thank the Savannah citizens who participated in the public meetings and provided comments for project completion. Review and assistance with the completion of this document was provided by Dan Brown and Jane-Coleman Harbison at the Tennessee Historical Commission.

### **City Commissioners**

**Robert E. Shutt, Mayor**  
**Blake White, Vice Mayor**  
**David Carroll, Commissioner**  
**Kent Collier, Commissioner**  
**Wes Wilkerson, Commissioner**

**Garry Welch, City Manager**  
**C. Seth Sumner, Assistant City Manager**  
**Will Radford, City Planner**  
**Roger Franks, Community Development Director**

### **Planning Commission**

**Jerry Rogers, Chairman**  
**Joe Cromwell**  
**Leroy White**  
**Blake White**  
**Benny Austin**

### **Historic Zoning Commission**

**Jim Kerr**  
**Joe Cromwell**  
**David Cagle**  
**Ben Harmon**  
**John Ross**

### **Consultant**

Thomason and Associates, Preservation Planners, Nashville, Tennessee

The activity that is the subject of this publication has been financed in part with federal funds from the National Park Service, Department of the Interior. However, the contents and opinions do not necessarily reflect the views or policies of the Department of the Interior, nor does the mention of trade names or commercial products constitute endorsement or recommendation by the Department of the Interior. Regulations of the U. S. Department of Interior strictly prohibit unlawful discrimination in departmental Federally Assisted Programs on the basis of race, color, national origin, age or handicap. Any person who believes he or she has been discriminated against in any program, activity, or facility operated by a recipient of Federal assistance should write to: Director, Equal Opportunity Program, U. S. Department of the Interior, National Park Service, P. O. Box 37127, Washington, D. C. 20013-7127



# Table of Contents

<b>I. Introduction</b>	3
Savannah Historic Zoning Commission	4
Secretary of the Interior’s Standards	5
The Design Review Process	7
Savannah’s Application for Certificate of Appropriateness	9
Savannah’s Downtown Commercial Historic District	10
Intent and Purpose of Historic Preservation	12
Federal Tax Credits	14
Historic Preservation and Energy Efficiency	15
A Brief History of Savannah and the Historic District	19
<b>II. Site Features &amp; District Setting</b>	24
Public-Right-of-Way	24
Site Features & Plantings	25
Archaeology	26
<b>III. Commercial &amp; Institutional Buildings</b>	27
Building Types	27
Details	28
Commercial Building Guidelines: Masonry	29
Wood	32
Architectural Metals	33
Storefronts	35
Commercial Building Windows	37
Commercial Building Entrances and Doors	40
Commercial Building Roofs	42
Utilities & Energy Retrofit	43
Accessibility & Life Safety	46
Parking Lots	47
New Commercial Building Construction	48

<b>IV. Residential Buildings</b>	50
Architecture of the Historic District	50
Residential Design Guidelines: Windows and Doors	55
Porches, Entrances, and Balconies	59
Paint Exterior & Color	61
Roofs	63
Wood	66
Masonry	69
Exterior Lighting	71
Fences & Walls	73
Walkways, Driveways & Off-street Parking	76
Garage & Accessory Structures	78
Utilities & Energy Retrofit	80
Accessibility & Life Safety	83
<b>V. Residential New Construction</b>	85
Decks	85
Additions to Historic Dwellings	86
New Construction of Residential Buildings	88
<b>VI. Relocation or Demolition</b>	91
Relocation	91
Demolition	92
<b>VII. Appendices</b>	94
Resources for Technical Assistance	94
Glossary of Architectural Terms	95
Normal Maintenance Items	101
Minor Work Items	101

## I. Introduction

---

The Savannah Design Guidelines are intended to assist owners of properties within the locally designated historic district in preserving the historic character of their buildings. When planning renovation or alterations to the exteriors of their buildings, property owners can consult the Design Guidelines for direction in appropriate rehabilitation. The Savannah Historic Zoning Commission utilizes the guidelines in reviewing the appropriateness of proposed changes.

Cities across the nation designate local historic districts to help preserve historic commercial areas and neighborhoods. This designation applies an “overlay,” an additional layer, to the base zoning type. The overlay requires that proposed changes to exteriors of historic buildings must be reviewed by the local Historic Zoning Commission. In Savannah, there is currently one historic overlay district, located downtown. The review requirement overlays the B-2 General Business zoning and B-3 Central Business areas. The purpose of the historic district overlay is not to prohibit physical alterations to historic buildings or discourage the evolution of building use. Rather, the premise of a historic district overlay is to acknowledge that historic properties collectively convey a city’s cultural and architectural heritage. Therefore, Savannah’s Historic Zoning Commission reviews proposed exterior alterations to an individual building, in terms of the potential impact on the district as a whole.

It is important not to confuse locally designated historic districts with National Register historic districts. Design guidelines do not apply to National Register historic districts. Listing in the National Register is an honorary distinction with no restrictions on changes to a listed property. Locally designated historic districts are created in order to protect historic properties from insensitive alterations. Design guidelines assist owners of properties within local historic districts in appropriate maintenance and rehabilitation measures for their historic buildings. If the boundaries of a local historic district and a National Register historic district happen to coincide or overlap, design guidelines apply strictly to the properties within the local historic district overlay boundary.

### **Savannah Historic Zoning Commission**

The Historic Zoning Commission (HZC) was established by the Savannah City Commission to protect and preserve its local historic resources. The HZC was created in



*The City of Savannah utilizes a unique steamboat insignia, and the Savannah Historic District and downtown commercial area are identified through signage and historic markers.*



accordance with the Tennessee Code which empowered the City to enact the Savannah Zoning Ordinance and Official Zoning Map, and provide for its administration and enforcement. The Savannah Historic District is located in Savannah and encompasses sections of the the B-2 and B-3 Zones which are the General Business and Central Business Zones.

The HZC meets on the second Tuesday of each month. Meetings are open to the public and are the venue for design review for proposed projects. Members of the HZC are appointed for five-year terms based upon their special interest, experience or education in architecture, archaeology or history. The five members have rotating terms so that only one member changes per year.

The philosophy of design guidelines is based on the Secretary of the Interior's Standards for Preservation and Rehabilitation. These standards form an over-arching principle of retaining and preserving historic fabric to the maximum extent possible. While property owners within the Savannah National Register Historic District are not required to have changes to their properties reviewed by the HZC, the Design Guidelines provide valuable information on the principles of maintaining a historic property. This preservation principle recommends the following hierarchy of treatment of materials and finishes:

- (1) identify, retain, and preserve;
- (2) protect and maintain;
- (3) repair;
- (4) replace in kind when too deteriorated to be repaired.

Design Guidelines utilized across the country reflect this prioritization of treatment based on the Secretary of the Interior's *Guidelines for Rehabilitating Historic Buildings*, as described on the following pages.



*Downtown Savannah is a focal point of the historic district.*

## Secretary of the Interior's Standards

A national set of standards for the preservation of historic buildings, developed by the United States Department of the Interior in 1976, addresses the rehabilitation of historic buildings and serves as a model for the Savannah Historic Zoning Commission in their deliberations. (Building use, however, addressed in Standard 1, is not reviewed by the Commission). Listed below, the 1992 version of the Secretary's Standards advocates a hierarchy of appropriate preservation treatments; valuing ongoing protection and maintenance over more major treatments; valuing ongoing protection and maintenance over more major repairs and, in turn, valuing timely repair over replacement of historic features.

1. A property shall be used as it was historically or be given a new use that requires minimal change to its distinctive materials, features, spaces and spatial relationships.
2. The historic character of a property shall be retained and preserved. The removal of distinctive materials or alteration of features, spaces and spatial relationships that characterize property shall be avoided.
3. Each property shall be recognized as a physical record of its time, place and use. Changes that create a false sense of historical development, such as adding conjectural features or elements from other historic properties, shall not be undertaken.
4. Changes to a property that have acquired historic significance in their own right shall be retained and preserved.
5. Distinctive material, features, finishes and construction techniques or examples of craftsmanship that characterize a property shall be preserved.
6. Deteriorated historic features shall be repaired rather than replaced. Where the severity of deterioration requires replacement of a distinctive feature, the new feature shall match the old in design, color, texture and, where possible, materials. Replacement of missing features shall be substantiated by documentary and physical evidence.

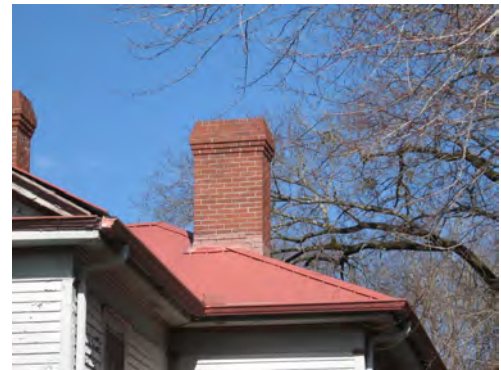

*The Secretary of the Interior's Standards promote replacing deteriorated features in-kind. This roof is an appropriate replacement (560 Main Street).*

7. Chemical or physical treatments, if appropriate, shall be undertaken using the gentlest means possible. Treatments that cause damage to historic materials shall not be used.

8. Archaeological resources shall be protected and preserved in place. If such resources must be disturbed, mitigation measures shall be undertaken.

9. New additions, exterior alterations or related new construction shall not destroy historic materials, features and spatial relationships that characterize the property. The new work shall be differentiated from the old and shall be compatible with the historic materials, features, size, scale and proportion, and massing to protect the integrity of the property and its environment.

10. New additions and adjacent or related new construction shall be undertaken in such a manner that, if removed in the future, the essential form and integrity of the historic property and its environment would be unimpaired.



*The Secretary of the Interior's Standards recommend preserving and restoring original features. Here the building's storefront and windows were conserved and re-used as part of the overall rehabilitation.*



### Savannah's Design Review Process

Prior to beginning any type of exterior construction, alteration, or demolition in the historic district, the property owner is required to obtain a Certificate of Appropriateness (CoA). The CoA verifies that the proposed changes have been reviewed by the Historic Zoning Commission (HZC) and are consistent with the design guidelines. Minor projects may be administratively reviewed by the Commission without a full review at the Commission's monthly meeting.

Application forms for a CoA and copies of the Design Guidelines are available at City Hall. The application must clearly describe the work that is being proposed and must include all necessary supporting materials. The form must be submitted to the HZC at least 16 days prior to the next meeting. The completed CoA application form may be scanned and emailed to the HZC or may be hand-delivered. Meetings occur at 5:30 p.m. at City Hall on the second Tuesday of each month.

For new construction, additions, and major site modifications, scaled drawings are required no larger than 11' x 17". A site plan must depict the entire lot with property lines and all setbacks clearly noted. For infill projects, footprints of buildings on adjacent properties must depict their relation to the proposed building. Plans must also show existing infrastructure (e.g., sidewalks, pavement, lighting, etc.) Floor plans are required, as well as a roof plan for complex additions or new construction. Samples of materials, manufacturer's brochures, current photographs, or other supplemental materials shall be provided if relevant. Property owners are encouraged to submit a preliminary plan early in the planning stages. An advisory committee can also be available to provide technical advice about preservation projects and restoration techniques at the request of the property owner.

For rehabilitation, scaled drawings illustrating the proposed work are required no larger than 11' x 17". Photographs of relevant facades, manufacturer's literature and samples are also required.



*Minor work would include the removal of original paint and repainting (470 Water Street).*

A proposed demolition must have similar scaled drawings accompanied by a written description and photographs of the structure's condition. Photos of interiors, accessory buildings, and site features are also required. The applicant must submit a written description the proposed new use of the site and plans for any new structure on the site.

In the case of a denied demolition proposal, the applicant may pursue economic hardship of the property, not the property owner. This determination reviews the estimated cost of demolition, a report from a licensed engineer, estimated market value of the property as-is plus improvements to meet basic codes, a professional estimate for rehabilitation costs of the property, amount paid for the property, relationship between buyer and seller, and date and terms of financing of the sale. For income-producing properties, the process requires annual gross income for the previous two years, itemized maintenance and operating costs, and depreciation deduction and annual cash flow before and after debt service.

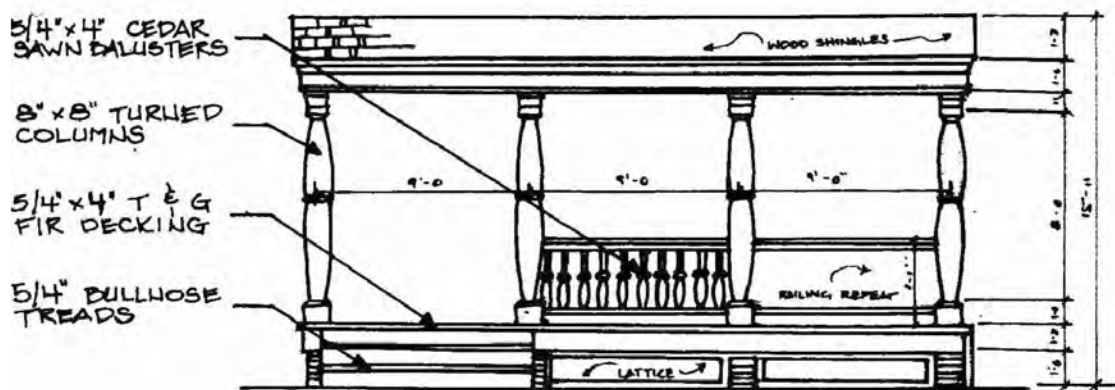

*Certificate of Appropriateness applications shall be accompanied by drawings sufficient to show the proposed design and dimensions of a feature.*



# APPLICATION FOR CERTIFICATE OF APPROPRIATENESS

Date Received: \_\_\_\_\_ By: \_\_\_\_\_

SAVANNAH HISTORIC ZONING COMMISSION  
140 Main Street, Savannah, TN 38372  
(731) 925-8007, (731) 926-1130 fax, rfranks@cityofsavannah.org

**DEADLINE:** Complete applications must be received a minimum of 16 days prior to the next HZC hearing which takes place on the second Tuesday of the month. Incomplete applications will not be scheduled.

**PROPERTY ADDRESS:** \_\_\_\_\_

**APPLICANT** (all communication by phone, fax, email or mail will be with the applicant)

Name \_\_\_\_\_

Mailing Address \_\_\_\_\_

City \_\_\_\_\_ Zip Code \_\_\_\_\_

Contact Phone \_\_\_\_\_ Fax Number \_\_\_\_\_ Email \_\_\_\_\_

Owner     Contractor     Architect/Designer     Other \_\_\_\_\_

**PROPERTY OWNER** (if different from applicant)

Name \_\_\_\_\_ Mailing

Address \_\_\_\_\_ City \_\_\_\_\_

Zip code \_\_\_\_\_ Contact Phone \_\_\_\_\_ Fax Number \_\_\_\_\_

Email \_\_\_\_\_

**TYPE OF WORK**     New Construction (Addition)     Demolition     Renovation     Other \_\_\_\_\_  
(Only exterior projects are reviewed.)

**DESCRIPTION OF WORK** (please use a separate sheet of paper for longer descriptions)

\_\_\_\_\_  
\_\_\_\_\_  
\_\_\_\_\_  
\_\_\_\_\_

Any substitution or deviation from the approved work items listed on the Certificate of Appropriateness requires further review and approval by the Historic Zoning Commission prior to being undertaken. Accurate scale elevations, drawings, and site plans are needed for project review. The HZC retains copies of all materials submitted.

**Estimated Cost of Work** \_\_\_\_\_

**Codes Department Building Permit #** \_\_\_\_\_

(This number starts with a "B" followed by the year. It may also be obtained later.)

**SIGNATURE** \_\_\_\_\_

**DATE** \_\_\_\_\_

I/We the above signed do hereby make application for a Certificate of Appropriateness following plans and proposals to be undertaken within the boundaries of an historic district overlay in the City of Savannah, Tennessee.

Review by:

*Copy of Savannah's Certificate of Appropriateness application form.*

**SAVANNAH'S DOWNTOWN COMMERCIAL HISTORIC DISTRICT**













Savannah's historic district overlays the central business center in downtown, as well as large portions of the area zoned Neighborhood Business. The district includes the blocks on the north and south sides of Main Street between North Riverside Drive on the west and Tennessee Street on the east. Parallel to and south of Main Street is Water Street, also included in the district from the river on the west to Tennessee Street on the east. The historic district encompasses 116 Individual properties.



*Coordinating design of street signs highlights the commercial district. .*



### Legend

	R-1	LOW DENSITY RESIDENTIAL
	R-1A	SINGLE FAMILY DETACHED
	R-2	MEDIUM DENSITY RESIDENTIAL
	R-3	HIGH DENSITY RESIDENTIAL
	R-4	HIGH DENSITY RESIDENTIAL/MOBILE HOME
	PURD	PLANNED UNIT RESIDENTIAL DISTRICT
	B-1	NEIGHBORHOOD BUSINESS
	B-2	GENERAL BUSINESS
	B-3	CENTRAL BUSINESS
	M-1	LIGHT INDUSTRIAL
	M-2	HEAVY INDUSTRIAL
		FLOODWAY
		A ZONE; AE ZONE

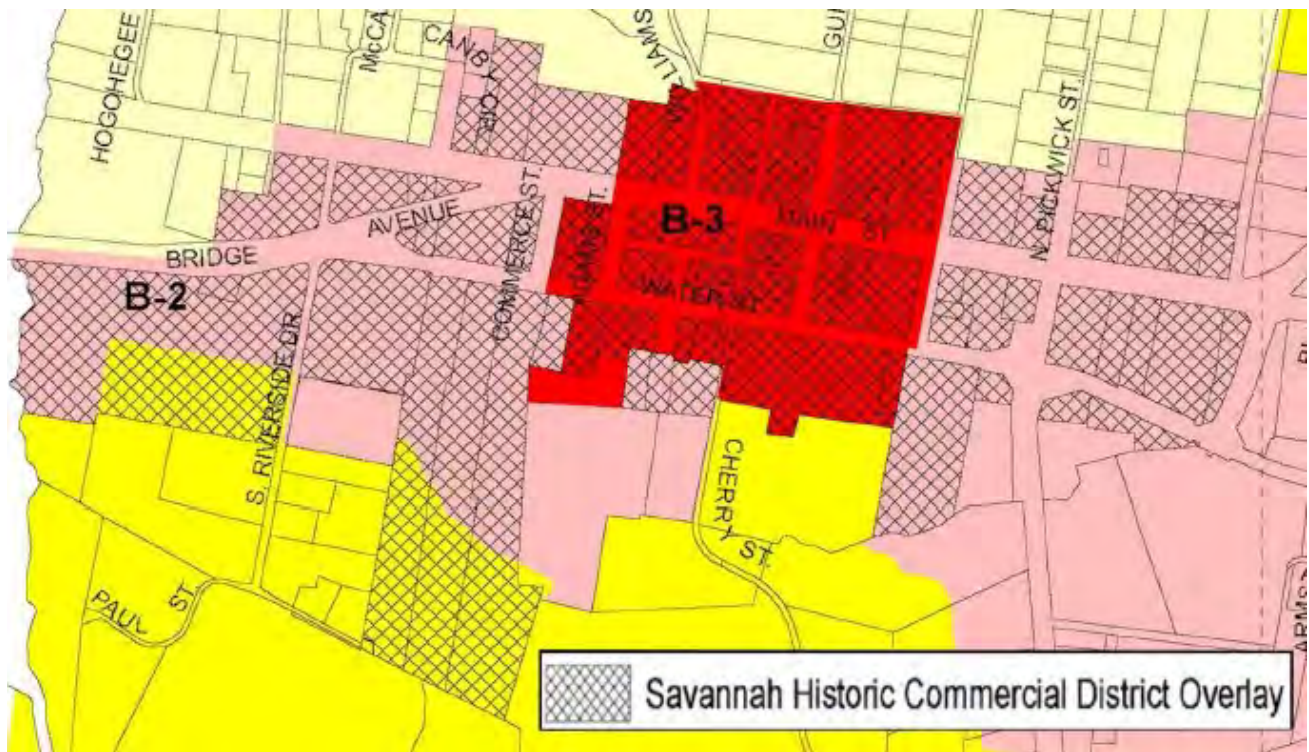

## Intent and Purpose

Historic preservation helps bridge together a community's past and future. Without a preservation model, Savannah's historic district would be at risk of losing its unique identity within ten to twenty years. Many people today visit their hometowns and lament the development that has made the built landscape unrecognizable. Design guidelines and HZC review provide a means for protecting Savannah's historic properties and helping direct the future evolution of these resources. Design guidelines give assurance to property owners that their investments will be protected. In turn, these historic resources build community identity.

## Why Preserve?

### *Historic Preservation Promotes Quality of Life*

A community differentiates itself through its historic buildings. Not only do they convey the town's past story, they often have second lives housing cultural amenities such as museums, theaters, and libraries. Many buildings within a historic district are not distinctive individually, yet as a group they form a tangible expression of the character of the historic district. The quality of the buildings and landscape reflect a community's self image; well-maintained and unique historic sections provide attractions to visitors and improve life for its residents.

### *Historic Buildings Often Last Longer than New Ones*

Often, buildings constructed before the 1960s are superior in materials and construction. In contrast, construction in the last 50 years is sometimes so poor that improvement and continued use of these buildings is often not economically justifiable. Pre-1960s buildings inherently possess greater sustainability and, after rehabilitation, may outlast new buildings.

### *Historic Preservation Supports Taxpayers' Investments*

A city's existing infrastructure - sidewalks, light fixtures, water and sewer lines, gutters and curbs, and roads and streets - represents taxpayers' public investments. Maintaining existing neighborhoods and infrastructure contains sprawl, which has consistently outspends the associated tax revenue, robs the landscape of green space, and increases commuting. A community that permits the decline of downtown and working neighborhoods is fiscally negligent. A city that maintains its historic neighborhoods is acting in the best interest of its taxpayers' investments.



*Downtown Savannah contains historic buildings with notable storefronts such as at 385 Main Street. This storefront features black Carrara glass, a tinted glass popular in the 1930s and 1940s.*



*Downtown's infrastructure includes streetscape improvements such as sidewalks, street trees and other plantings around the courthouse.*

### *Historic Preservation Creates Jobs*

Rehabilitation and revitalization projects create thousands of construction jobs annually, and historic preservation creates more jobs per capita than new construction. In a typical new construction project, about half of the expenses are for labor and half for materials. In a rehabilitation initiative, between 60 and 70 percent of expenditures are usually for labor. Because labor is often local, the economic benefits of rehabilitation are more likely to stay within the community, benefitting workers and the local businesses where they spend their money. Supplies are also likely to be purchased locally for rehabilitation projects, whereas new construction typically bring in supplies from outside.

### *Historic Preservation Increases Property Values*

Studies in communities across the country consistently evidence that listing of a property in the National Register increases property values. Properties within National Register and local overlay historic districts tend to have higher property values than adjoining areas that lack historic designation, even with similar architecture.

### *Historic Preservation Attracts Visitors to Cities*

Visitation to historic sites – known as heritage tourism - is a rapidly growing segment of the tourism industry. Heritage tourists tend spend more time and money than other types of tourists, boosting the economy in the communities they visit. Historic architecture enhances tourism by reinforcing the city's sense of place.

### *Historic Preservation Benefits Property Owners*

Design guidelines help protect historic properties from inappropriate new construction or remodeling. Because the value and character of each property is influenced by the actions of its neighbors, design review helps protect the overall value and character of a neighborhood by providing consistent and proven guidance for treatment of properties.



*Heritage tourism brings millions of visitors to the state every year. Savannah's Tennessee River Museum, located in the city's historic Post Office is a tourism center in Savannah.*

## Tax Incentives for Preservation

### Federal Tax Incentives for Rehabilitation

A federal rehabilitation tax credit is available for properties listed in the National Register if they are used for the production of income. This tax credit equals 20% of qualified rehabilitation expenditures. This applies to rehabilitation for housing, retail, offices, and other income-producing uses. Property owners who wish to utilize the rehabilitation tax credit must follow the *Secretary of the Interior's Standards for Rehabilitation* and the *Guidelines for Rehabilitating Historic Buildings*. The *Standards* and *Guidelines* provide guidance to property owners, architects, developers, and reviewing agencies in the rehabilitation of a historic buildings. The design guidelines for Savannah are based upon those documents.

During the past three decades, the federal historic tax credit has revitalized communities and created 2.2 million jobs through the rehabilitation of more than 38,000 historic buildings. From 2001-2011, \$81.9 million in federal tax credits catalyzed 132 projects in Tennessee, totaling \$409.4 million in qualifying rehabilitation expenditures. Communities across the state of utilized the tax credit as a tool for rehabilitating historic downtown commercial centers, bringing new life to downtown streets.

Most of the properties in downtown Savannah contribute to the character of the historic district and would qualify for the federal tax credit. In addition to rehabilitation for businesses on the first floor, property owners might also want to consider the addition of office spaces or apartments on the upper floors to maximize their investment and tax credit. Many of the buildings have vacant upper floor space that could be utilized for income-producing purposes.



*Income-producing buildings on Main Street that contribute to the character of the district may be eligible for the federal rehabilitation tax credit.*



## HISTORIC BUILDINGS AND ENERGY EFFICIENCY

### Introduction

One of the design guideline's main objectives is to preserve the city's unique heritage, and also encourage the adaptive reuse of historic buildings. By encouraging the maintenance and re-use of existing buildings, preservation represents the broad philosophy of recycling. Therefore, historic preservation is inherently "green." In past decades, the traditional focus of preservation focus was on the aesthetic and cultural significance of historic buildings. Recently, as communities consider how to grow responsibly, preservation has become a tool for promoting values of energy-efficiency and sustainability.

### Embodied Energy

In seeking innovative designs, architects and developers today often embrace the use of "green" practices and materials in new building construction. Yet, the bottom line is that new construction requires a new expense of energy. From the extraction of raw natural materials, to their transportation, manufacture, and distribution, to the physical act of construction, energy is spent. In contrast, an existing building represents the physical embodiment of energy, already spent. This energy, in the inert form of a building, remains in place as long as the building stands. If razed, the building's embodied energy is lost; the very demolition represents an expenditure of new energy. Loading and hauling the building debris to a landfill requires additional energy and loss of resources. Thus, an existing building is literally a mass of invested energy. Demolishing a sound building squanders that investment.

### Working with Nature: Site Orientation

Pre- World War II buildings were designed, constructed, and sited in relation to the natural environment. Their materials, placement, and architectural elements optimized ventilation, insulation, and use of daylight. For example, windows on a south elevation, allow maximum natural light into the interior and also provide passive solar heat during winter months. During summer months, these windows could be shaded with removable awnings to block heat. Storefronts were also designed to allow sunshine into the interior in the winter and block the summer heat through retractable awnings.

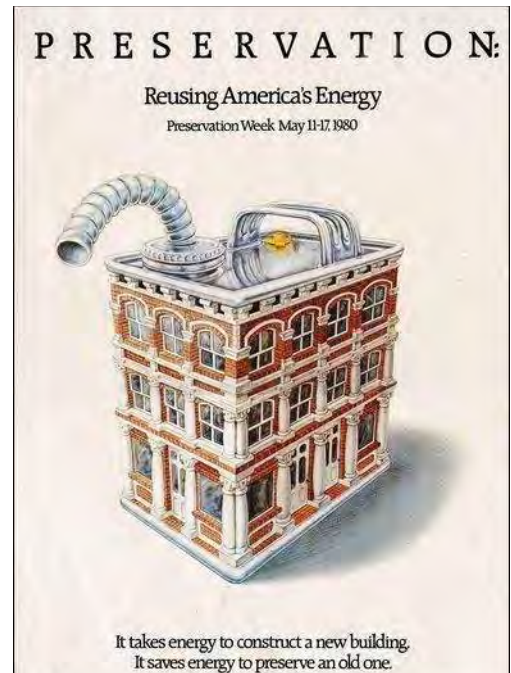

*Embodied energy is illustrated in these two images showing the energy inherent in a historic building and how much energy is in eight bricks (courtesy National Trust for Historic Preservation).*

The thick masonry walls of older buildings help retain interior heat in the winter and also help lengthen the time it takes for summer heat to penetrate the building. Form-to-function architectural elements include operable transoms and high ceilings, which allow the escape of hot air. Since World War II, the availability of amenities such as electricity, synthetic insulation, and central heating and air conditioning systems have become standard installations, eliminating the need for attention to the natural environment. As a result, the quality and longevity of building materials also became less important, as modern conveniences can control the interior climate of buildings, and materials were available to build anew.

### **Inherent Energy Efficiency of Older Buildings**

It logically follows that the traditional considerations of construction produced building stock of inherent energy-efficiency. Data from the U.S. Energy Information Agency found that buildings constructed before 1920 are actually more energy-efficient than those built during the last two or three decades of the twentieth century. Only in recent years, as consumers started considering their energy use, have builders begun to design more energy-efficient buildings. Yet, contrary to common thought, these newer buildings often use more energy because they are not designed to take advantage of the natural benefits of their site.

### **Retro-fitting and Weatherization**

One hundred-year-old buildings often have inherent energy-efficient design features. Still, numerous windows and minimal insulation can result in energy losses in older buildings. Some homeowners have resorted to installing synthetic sidings, replacing original windows, and enclosing porches. These actions may gain energy savings, but result in the loss of a property's historic character. Owners of historic buildings need not compromise their historic character for improved energy efficiency. Simple non-altering upgrades to historic buildings include the addition of attic insulation, installation of storm windows, and more efficient heating and cooling systems. In particular, repairing and weatherstripping historic wood windows and adding storm windows often result in energy performance equal to or exceeding that of new windows and at much less cost. Installing new windows becomes a cycle, as they have a finite life; and rarely do they pay for themselves in energy savings over their life of use.



*Adding attic insulation is often the most important method to insulate historic buildings and save on energy costs.*



A systematic assessment of energy-efficiency can benefit any building. Upgrades can range from simple weatherstripping to installation of new technology products such as geo-thermal heating/cooling systems and solar roof tiles. Furthermore, many of the methods for improving energy efficiency of a historic or older building can be performed without the need for review by the HZC, whereas requests for replacement and removal of historic architectural components may require review.

### Retain Your Old-Growth Windows and Save Energy and Money

Property owners may think that they can gain more energy efficiency by replacing their original windows. Yet replacement of historic wood windows can cost more than implementing weatherization practices. Sealing air leaks is as easy and inexpensive as caulking around window and door frames and installing storm windows. In fact, rebuilding historic wood windows and adding storm windows can equal or exceed the insulating value of new windows and more than offset the cost of replacement.

Another plus for retaining historic wood windows lies in the longevity of their old-growth lumber, which can last indefinitely when properly maintained. Removal and replacement of original windows represents the loss of embodied energy. It is important to consider that vinyl replacement windows are not as durable and will eventually require wholesale replacement. All windows expand and contract with temperature change. Vinyl expands more than twice as much as wood, resulting in failed seals between the frame and glass and a significant performance reduction. Vinyl windows have a high failure rate – more than one-third of all vinyl windows require replacement within ten years of original installation. Any energy savings from replacing wood windows with vinyl seldom justifies the costs of installation.

For more information on window preservation go to the Preservation Green Lab’s “Saving Windows, Saving Money” This study compared retrofit and replacement options for older wood windows and finds retrofit measures can achieve performance results comparable to new replacement windows. Similar studies were completed by the Window Preservation Standards Collaborative and can be viewed at [windowstandards.org](http://windowstandards.org).

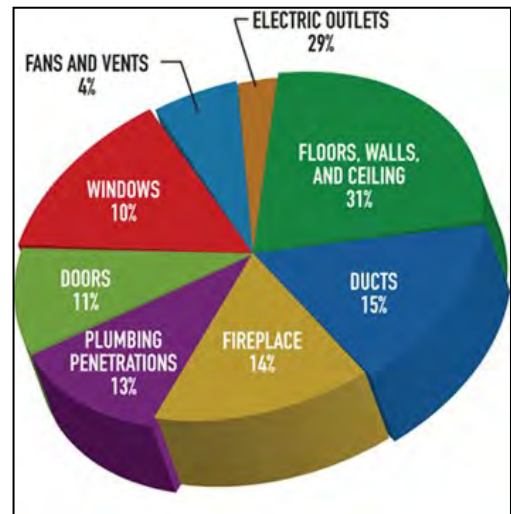

*Energy loss through windows is much less of a factor than other parts of a building (courtesy U.S. Department of Energy).*



*Replacing historic windows with vinyl windows is neither cost effective or compatible with a building’s historic character.*

### Use of Alternative Materials

The use of alternative materials in the Savannah Historic District will be considered by the HZC and staff. The design guidelines promote repairing original features. Only when historic elements are beyond repair shall they be replaced with similar materials. The use of synthetic materials such as vinyl siding and vinyl windows is generally discouraged or not approvable since these materials can be incompatible in their appearance, profile or texture with historic building features. However, with increasing concerns over sustainability and the expense and unavailability of traditional historic materials, the HZC will consider and review requests for the use of alternative materials within the historic district.

Materials that may be appropriate include:

1. Cementitious siding for new construction and new outbuildings. The use of cementitious siding will also be considered for repair or replacement on rear or side elevations not readily visible from the street. However, cementitious siding never appears congruous when used as in-kind replacement for wood siding and shall not be used as such.
  2. Fiberglass porch columns that are compatible with the original style and materials of a dwelling. This would be in circumstances where the original porch columns are no longer extant or when the applicant can demonstrate to the satisfaction of the HZC that the existing porch columns are no longer repairable.
  3. Recycled plastic and wood materials (composites) that are compatible for the replacement or repair of porch floors or other wood features.
  4. Synthetic slate composed of ceramic, asphalt or fiberglass or other composite materials. These materials would only be allowed if the applicant can demonstrate to the satisfaction of the HZC that the existing slate roof is not repairable and that the proposed synthetic materials would closely match the existing slate.
  5. Aluminum clad windows with enamel finishes that closely match the original in profile and dimensions. Replacement of original windows is appropriate only if the applicant demonstrates that the original windows are not repairable or no longer extant.
1. Other alternative materials demonstrated to be compatible and sustainable with historic features.



*Fiberglass columns and railings as shown above may be appropriate for dwellings when the original columns are no longer extant or if repair is not possible.*



*Synthetic slate is available in a wide variety of materials and finishes.*

## A Brief History of Savannah and the Historic District

Prior to Euro-American settlement of present-day Hardin County, the dense forests and cane brakes surrounding the river served as abundant hunting grounds for Native peoples. Along the east side of the Tennessee River was an earthworks measuring 1,385 by 550 yards with a projecting redoubt every eighty yards. Between this trench and the river were seventeen mounds. The site was surveyed in 1871 and was later classified as a Middle Woodland-period ceremonial complex thought to have been constructed between 50 B.C. and 200 A.D.

During the settlement period, three large land-grant surveys were made, one for Colonel Joseph Hardin in 1786. Euro-Americans moved into this part of Tennessee during this time. By the nineteenth century, this area was inhabited by the Chickasaws and claimed by both the Chickasaw and Cherokee tribes. In 1805 and 1806, these tribes ceded most of the area of Middle Tennessee south of the Duck River to the Alabama line and west to the Tennessee River. However, the Chickasaws finally opened the east part of the future Hardin County for settlement. The great Chickasaws cession of 1818 opened the rest of Tennessee, that between the Tennessee and Mississippi Rivers, for settlement.

Hardin County was created by an act of the State Legislature in 1819. This being accomplished, the first Hardin County Court met in the home of James Hardin at Hardinsville in January of 1820. In 1822 the seat of government was moved to a more centralized location also named Hardinsville in honor of the Hardin family. That place today is known as Old Town.

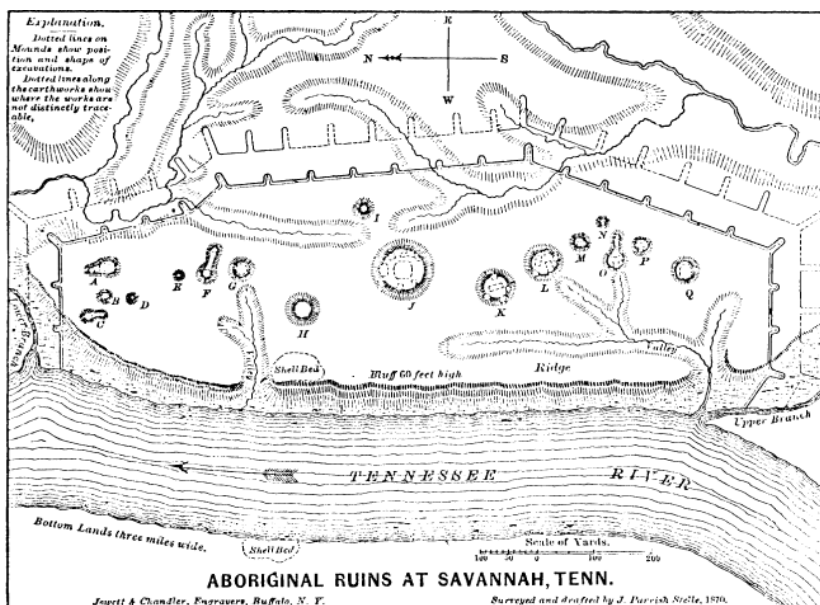

*Diagram of Native-American earthworks at Savannah from a ca. 1870 survey by J. Parish Stelle.*

In 1825, a private act was passed by the State Legislature to move Hardinsville to a site on the Tennessee River which would be more accessible to the County's citizens. The site, known as Rudd's Ferry, was chosen and Hardinsville was moved there. In 1827, a private act was passed that changed the name from Hardinsville to Savannah. The naming of Savannah was attributed to the wife of David Robinson, her family being natives of South Carolina, living near the Savannah River.

The area developed an agricultural economy based mainly on corn, hay, and cotton. Timber was also an important source of income. Hardin County had 1,462 residents in 1820. The population jumped 233 percent to 4,868 by 1830. In that year, local planter David Robinson built a Greek Revival-style mansion in the confines of an ancient Native-American town overlooking the Tennessee River. By 1850, the population of Savannah had reached 466, while the concurrent population of Hardin County was 10,328.

Prior to the Civil War, the majority of county residents opposed secession. However, after the firing on Fort Sumter, county residents raised a full cavalry regiment and also organized infantry units for the Confederate cause. After the fall of Fort Donelson, Tennessee Governor Harris ordered out all available men, and Hardin County organized five companies that were stationed in Savannah. In 1862, Hardin County was the site of the Battle of Shiloh (also known as the Battle of Pittsburg Landing). The two-day battle was a major event of the western theater of the war, with 65,000 Union troops and 44,000 Confederate soldiers involved. The battle resulted in 24,000 soldiers killed, wounded or captured. Savannah was the headquarters for Union General Ulysses S. Grant and the community housed wounded soldiers for many



*Shiloh was a pivotal battle in the early years of the Civil War as depicted by artist Henry Ogden.*



*1974 photo of the east façade of the Cherry Mansion at 1010 Main Street.*

### **The Cherry Mansion**

The ca. 1830 Cherry Mansion was built by David Robinson, an early settler of Hardin County. In 1842, Robinson's daughter Sarah married William Harrell Cherry and was given the mansion as a wedding gift. The Greek Revival-style dwelling served as headquarters for Union General Ulysses S. Grant in the spring of 1862. Oral history indicates that couriers interrupted Grant's breakfast with the news of the outbreak of the Battle of Shiloh. Another account maintains that Grant and his staff heard distant cannon fire, alerting them to the battle seven miles away. Grant and his men then boarded a steamboat at a landing below the dwelling and reached the battlefield via the river. A monument noting Grant's headquarters stands two blocks from the property.

After the war, the Cherry family employed Alex and Queen Haley, grandparents of famed *Roots* author, Alex Haley. The property was listed in the National Register of Historic Places in 1977. The Cherry Mansion is open for scheduled tours with an admission fee.



*Photo of the west façade of the Cherry Mansion from the 1974 Historic American Buildings Survey.*

After the Civil War, the economy of Hardin County continued to be based in agriculture. The grounds of the Agricultural & Mechanical Association of Hardin County were purchased in March, 1872, and the first fair was held in 1873. The fairgrounds were located immediately south of Savannah. The five-acre tract included an amphitheater with seating capacity for 6,000 to 8,000 people. At the time, the population of the county was over 12,000. This number grew to 14,793 in 1880.

The county's population peaked at 19,246 in 1900 before beginning a gradual decline. Though the creeks and streams of the county historically helped to develop the timber and mill economy, the first bridge across the Tennessee River was not built until 1930. In that year the Milo Lambert Bridge at Savannah was the first to span the river in Hardin County. The river influenced another important milestone in the history of the county, when the Tennessee Valley Authority (TVA) constructed the Pickwick Landing Hydroelectric Dam south of Savannah. The project required the purchase of tens of thousands of acres, displacing 500 county families.

TVA brought progress to the rural county. The project provided temporary employment to workers who helped clear the land. These workers also received agricultural training. The TVA implemented soil conservation practices on lands leased to local farmers and instructed them in cultivation of winter legume crops that would replenish the soil. Data collected on local fish populations influenced limit regulations. Most importantly, TVA brought cheap electricity to the county, improving the quality of life and influencing new recreational and manufacturing opportunities.



*Early photo of Savannah (Photo from rootsweb.ancestry.com).*



Like many rural Tennessee counties, Hardin County's population decreased in the early 20th century but gained after World War II. Savannah experienced a doubling of its population from 1,698 in 1950 to 4,313 in 1960 as new industries came to the county. In 2010 the city's population was recorded at 6,982 residents.

In the late 20th century the city made numerous improvements to downtown and the older residential areas. Historic markers were erected in front of many of the homes in the National Register Historic District and new sidewalks, light fixtures and other amenities were added downtown. The commercial area retains many of its historic buildings and the U.S. Post Office, built in 1939, was converted into the Tennessee River Museum. The city is a tourism center, particularly for those interested in the Civil War and the nearby Battle of Shiloh. In recent years the city government has worked to improve downtown through participating in the state's Main Street Program.



*Downtown's Main Street within the local historic overlay district, ca. 1940 (top) and today (bottom).*



---

## II. Site Features & District Regulations

---

The overall character of the Savannah Historic District is defined by its collections of buildings and structures, which are unified by connective public areas and street fixtures. These public areas consist of the public parks, median strips, streets, streetlights, traffic signs, sidewalks and the area between the sidewalk and the street. The Town of Savannah and TDOT are responsible for this public-right-of-way and its ongoing maintenance.

Public-right-of-way has evolved over time, yet much of the historic character of downtown remains. Today, paved streets, sidewalks, and streetlamps enhance the streetscape and contribute to the character of the Savannah Historic District. The city shall always consider the effects of future changes with respect to this character. Beyond routine maintenance and repair, changes to the public-right-of-way – including new plantings, utility equipment, signage, benches and sidewalks – shall all be reviewed for compatibility in terms of location, materials, design, color and scale.

In most cases the HZC will normally require the following:

1. Retain and preserve the historic features, patterns, materials, topography and configuration of streets, sidewalks, trees and plantings in the public-right-of-way that contribute to the overall character of the Savannah Historic District.
2. Protect and maintain historic streetscape materials and features, such as curbing and street plantings, when construction work or street repairs are necessary.
3. Repair historic streetscape materials and features, including sidewalks, curbs and paving, as necessary, in materials compatible with existing materials in designs, color, pattern and texture.
4. Replace historic streetscape materials and features in kind only if they are too deteriorated to be repaired. It is not appropriate to replace granite curbs with concrete curbing.
5. Trim and prune trees within the public-right-of-way in such a way that the existing tree canopy is preserved. It is not appropriate to diminish the streetscape canopy by tree topping.



*Appropriate light fixture on Main Street.*

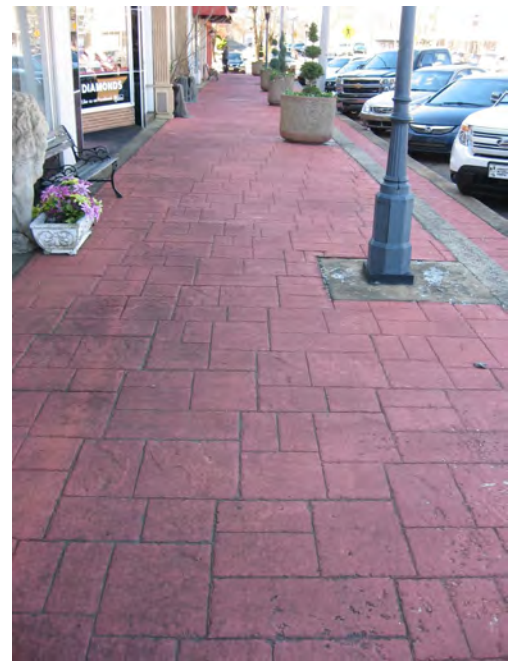

*Patterned concrete sidewalks in the Savannah Historic District.*

6. Maintain the existing planting strips along the public-right-of-way. It is not appropriate to pave over existing planting strips.

7. Introduce new and replacement street trees to retain the spacing and pattern of the tree canopy in the district.

8. Introduce new plantings and trees in the public-right-of-way that are compatible with the overall character of the historic district and are compatible with any overall landscape plan for the district.

9. Keep the addition of new utility poles, cables, transformers and wires to a minimum in the public-right-of-way. Locate necessary equipment in the least intrusive locations so they do not diminish the overall character of the historic district and, when possible, place new utility lines underground.

10. Limit signage in the public-right-of-way to signs necessary for traffic and public safety. Locate such signage with care so that its impact on the character of the historic district is minimized.

11. Select street light fixtures that are compatible in design, materials and scale with the overall character and pedestrian scale of the historic district.

12. Select street benches, trash receptacles, fountains and other street furniture that are compatible in design, size, scale, materials and color with the overall character of the historic district. Locate such elements in location that do not compromise the character of the historic district.

13. The installation of freestanding mail boxes on sidewalks in the commercial district is incompatible with downtown's historic character and will not be approved. Mailboxes may be located on the main façade wall adjacent to the entrance if necessary. Such mailboxes should be as small and unobtrusive as possible. The use of existing mail slots in front doors or the retrofitting of existing doors with mail slots is encouraged.



*Appropriate street furniture on Main Street.*



*Public benches, planters, and waste receptacles are of simple design.*

## Archaeology

---

An “archaeological resource” is defined as any material evidence of past human life found below ground surface, portions of which may be visible above ground. Historic districts, by nature, contain a wealth of archaeological resources, which can reveal information about the historic property and the lifestyle of earlier residents. They can disclose the location and footprint of original foundations, porches, walkways, gardens and accessory buildings.

Additionally, the area west of downtown Savannah is a site where Native American earthworks, relics, and human remains have been found. The potential for additional Native-American artifacts is high. These resources could be unknowingly destroyed during the process of site grading or new construction. Professional site investigation is highly recommended prior to any earth-moving or construction. The Tennessee State Historic Preservation Office offers assistance to property owners who are concerned that planned site changes will endanger potential archaeological resources or when such a resource is uncovered. Maintaining such resources *in situ* – in their original place – is the best preservation. Sanborn Insurance maps exist for Savannah which illustrate the downtown area from 1930 and 1940. These maps are highly detailed and show the location of residential and commercial buildings in the downtown area as well as outbuildings in rear yards.

In most cases the HZC will normally require the following:

1. Retain, preserve and protect in place any known, significant archaeological resources.
2. Minimize ground disturbances and site changes that affect the site terrain of historic properties and districts to lessen the possibility of destroying significant archaeological resources.
3. Work with professional archaeologists in planning and executing any archaeological investigations if preserving archaeological resources in place is not feasible.

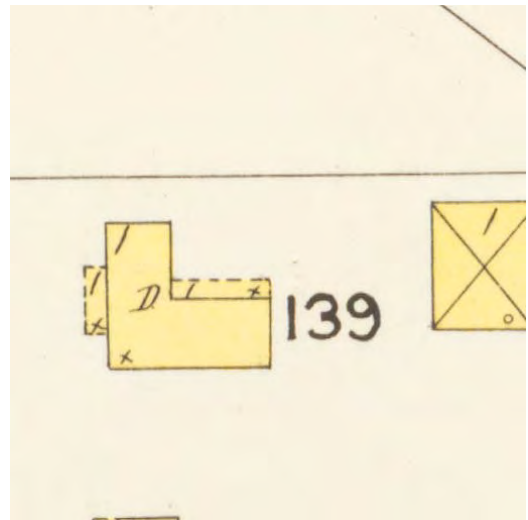

*Sanborn Insurance Maps can provide information on the original location and profile of buildings in Savannah.*

---

### III. Guidelines for Commercial Buildings

---

#### Types:

#### Two-Part Commercial Block

Many of the commercial buildings in downtown Savannah can be characterized in form as “Two-Part” commercial blocks. These are buildings that have two primary components – storefronts and upper facades. For display purposes, original storefronts are designed to be transparent, with large areas of windows resting on bulkheads, transoms, and entrances with glass and wood doors. Upper facades have one or more floors of windows and decorative detailing such as brick corbelling, or terra cotta panels and cornices at rooflines.



*Two-Part commercial block building at 390 Main Street.*

*390 Main Street*

#### One-Part Commercial Block

A one-part commercial block building consists of a single story that functions like the lower story of the two-part commercial block. Above the display windows of the storefront there may be a decorative rectangular inset and a decorative cornice at the roofline. Traditionally, this area below the roofline was the place for the business sign.



*One-Part commercial block building at 430 Main Street.*

---

## Commercial Building Details

---

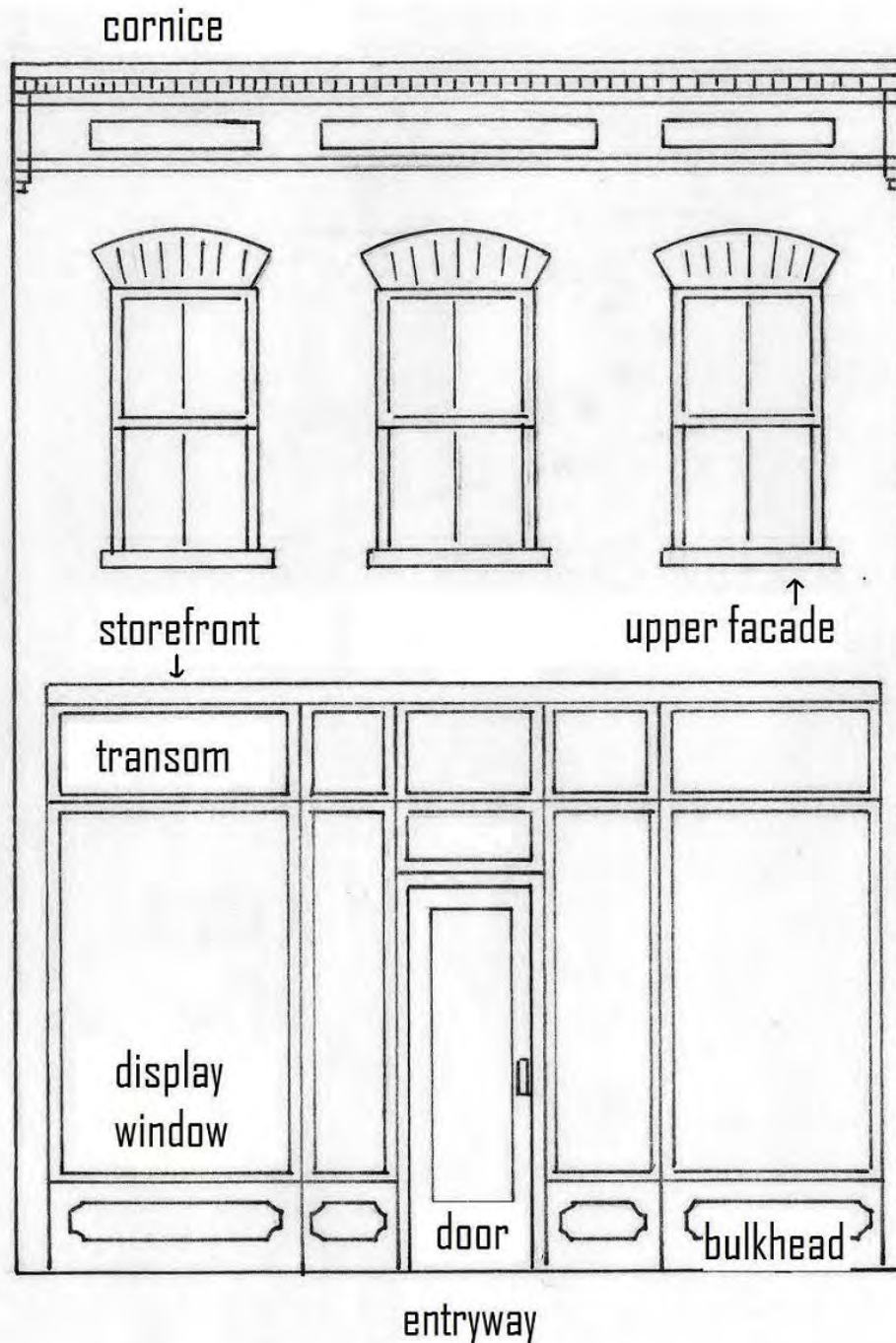

*This drawing shows a typical late nineteenth and early twentieth century commercial building and identifies some of its components.*

---

# Commercial Building Guidelines

---

## Masonry

---

Brick, native stone, terra cotta, slate, tile and stucco are examples of masonry materials used for commercial buildings, including their walls, steps, foundations, and chimneys. The characteristics of masonry surfaces that contribute to the overall appearance of a historic building include texture, scale, color, bonding pattern, joints and details. Brick and native stone are by far the most common masonry materials found in the Savannah Historic District.

Masonry foundations are also typical in the Savannah Historic District. Foundations are often distinguished from the walls they support by a change in material, pattern or texture – a water table or distinctive band of brick. Some foundations have been painted.

Masonry surfaces are often long-lasting with minimal maintenance required. In fact, cleaning is recommended only if dirt or organic matter is actually accumulating and promoting deterioration by holding moisture on the masonry surface. If cleaning is necessary, use the gentlest methods possible. High-pressure cleaning techniques such as sandblasting or waterblasting do permanent damage to the surface of historic masonry and, therefore, are not appropriate. The most common cause of masonry deterioration is not dirt, but moisture. If water can enter the wall, roof foundation or chimney through loose masonry joints or cracks, it will cause penetrating damage.

The most common type of maintenance for masonry surfaces is periodic repointing – the process of replacing weakened mortar joints with new mortar. It is important to match the new mortar with the original in strength, texture, color, width and tooling profile and to avoid smearing mortar on the masonry surface. Generally, parging and above-grade, water-repellent coatings are not recommended. Water penetration to the interior of masonry buildings usually is caused not by porous masonry but by deteriorated gutters and downspouts, deteriorated mortar, capillary moisture from the ground (rising damp) or condensation. Usually, if these conditions are addressed, coatings and sealers are not necessary. In



*Stepped or “corbelled” brick courses were used to decorate several buildings in the downtown area such as at 45-55 Court Street.*



*By the mid-20th century, long and thin masonry known as “Roman brick” was used as the exterior surface for some downtown buildings such as at 160-168 Guinn Street.*

fact, they may cause greater deterioration of the masonry by trapping moisture inside the wall. In addition, coatings may change the color and reflective property of the masonry. Property owners need to carefully evaluate any water penetration problems before using above-grade water repellents.

In most cases the HZC will normally require the following

1. Retain and preserve historic masonry materials and features, including their color, texture, pattern, and detail, that contribute to the overall historic character of a building, site or district, including chimneys, foundations, walls, steps, retaining walls, walkways and terraces.

2. Maintain and protect historic masonry materials, features and details through appropriate maintenance, cleaning and repair methods as needed.

- ❑ If gentle cleaning methods such as low-pressure washing are unsuccessful, chemical cleaners may be appropriate provided that the most gentle are used first. Test chemical cleaning or paint-stripping techniques on an area hidden from view before applying the product generally. Never attempt the use of destructive cleaning techniques such as power washing, sandblasting or high-pressure waterblasting on historic masonry.
- ❑ Do not paint or coat historic masonry surfaces unless they were previously painted or coated. Repaint previously painted masonry surfaces in colors that are appropriate to the building or site feature.

3. Repair historic masonry mortar joints by repointing them if the mortar is deteriorated or missing, or if there is evidence of moisture penetration. Carefully remove loose and deteriorated mortar, using hand tools, prior to repointing. Repoint mortar joints with new mortar that matches the original in color, composition, strength, tooling profile, and texture, duplicating the appearance of the original mortar joint. Power tools can be used if workers are properly trained. Consider masonry coatings and water repellents only if traditional repointing and repair techniques are not successful.

4. Replace deteriorated or damaged historic masonry materials and features, only if they are damaged beyond repair, in kind – matching the original in material, design, dimension and detail. Where possible, limit replacement to the deteriorated section only, rather than the entire

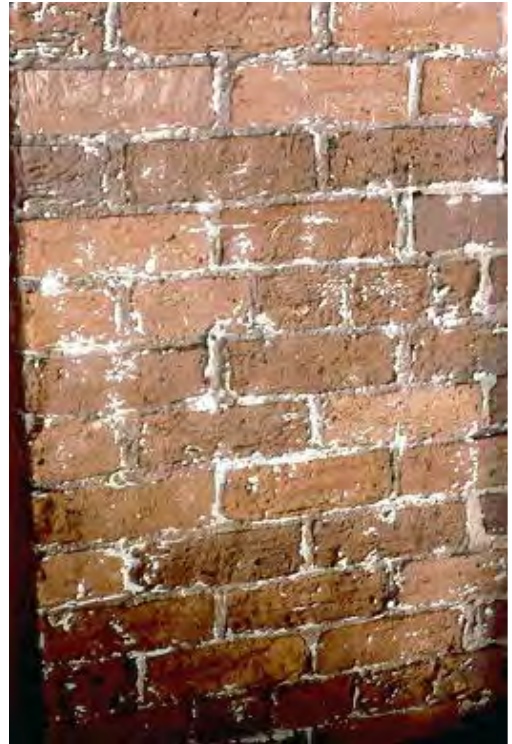

*Abrasive cleaning removes the exterior patina or “crust” of the brick allowing the soft brick interior to peel away. No abrasive cleaning shall be used on Savannah’s buildings.*



feature. Consider compatible substitute materials only if it is not technically feasible to replace in kind.

5. Replace a missing masonry feature with a new feature based upon accurate documentation of the original feature. A new design that is compatible in material, design, color, size and scale with the historic building or site may alternatively be appropriate. Do not install new masonry features in an attempt to create a false historic appearance.



*The ca. 1931 building at 250 Guinn Street is constructed of stone veneer, another masonry type within the historic district.*



*The exterior walls at 470 Water Street are rock-faced concrete block. The guidelines for masonry apply to brick, stone, and block surfaces.*

## Wood

---

In the downtown commercial area wood is primarily used as an exterior material for storefronts and windows. It is important to maintain and repair wood features as needed. Routine maintenance includes caulking and sealing vertical and exposed wood joints. The key to preservation is the prevention of the entry of water beneath the wood surface; painting the surface protects it from exposure to the elements. Repair or replace decaying boards and other wooden elements through splicing or piecing. Take care to select replacement wood that matches the design and dimensions of the original. Wood epoxies that stabilize and save a damaged or decayed feature in place may be the best solution for preserving difficult-to-replicate, distinctive features.

In most cases the HZC will normally require the following:

1. Retain and preserve historic wood materials and features, including their color, dimension, texture, pattern, form and detail. that contribute to the overall character of a commercial building including exterior trim, storefronts, windows and doors.
2. Maintain and protect historic wood surfaces, materials, features and details through appropriate maintenance, cleaning and repair methods as needed.
3. Repair historic wood features and materials using traditional preservation techniques, including patching, splicing, reinforcing and consolidating.
4. Replace historic deteriorated or damaged wood features and materials, only if deteriorated beyond repair, in kind – matching the original in material, design, dimension and detail. Where possible, limit replacement to the deteriorated section only rather than the entire feature.
5. Replace a missing wood feature with a new feature based upon accurate documentation of the original feature or a new design compatible in material, design, color, size and scale with the historic building or site.



*The building at 409 Main Street has an original historic wood door and wood surround with sidelights and transom.*

## Architectural Metals

---

Architectural metals are common elements on historic commercial building and include cast iron, wrought iron, pressed tin, copper, brass, bronze and aluminum. These materials are primarily located in the downtown area in the form of sheet metal cornices and metal bulkheads. There may also be cast iron columns or pilasters hidden beneath added storefront materials. These features contribute to the character of historic buildings and sites through their distinctive shapes, textures and details.

Retention and care of original architectural metals are important in preserving the historic character of the building or site feature. Regular attention to the physical condition of metal surfaces will prevent deterioration due to corrosion, fatigue or water damage. Metal roofs and gutters require routine cleaning of debris and leaves to prevent deterioration. A protective paint film is essential for ferrous metals in combating corrosion and rust. If the film deteriorates, corrosion begins. Then the loose rust must be removed and the surface immediately primed with a zinc-based primer or other rust-inhibiting primer to prevent additional corrosion. Non-ferrous metals such as copper, brass and bronze do not require the protection of paint, and their inherent patinas are valued.

The softness of metal determines the appropriate cleaning method or substance. For example, soft metals, including copper, tin, brass, aluminum and lead, may be cleaned chemically. Hard metals like cast or wrought iron and steel can stand up to the abrasion of careful wirebrushing or hand scraping necessary for cleaning. Harsher abrasive techniques, such as low-pressure grit blasting or glass bead blasting, may only be used on cast iron or steel surfaces if gentler techniques are unsuccessful. These techniques are not appropriate for other historic metals.

Always try to repair damaged metal instead of replacing it. However, if replacement is necessary, make every effort replace the metal in kind. If this is not possible, appropriate substitutions may be considered. For example, a fiberglass or wood detail might be substituted for a missing decorative, painted metal detail.

In most cases the HZC will normally require the following:



*This original sheet metal cornice at 406-408, Main Street is well maintained and is a major feature of this commercial building.*



*The exterior walls at 585 Cherry Street are covered with pressed tin panels that mimic rock-faced concrete block.*

1. Retain and preserve historic architectural metal materials and features, including their dimension, pattern, form, color, texture and detail, that contribute to the overall character of Savannah's commercial buildings including cornices, gutters, downspouts, and hardware.

2. Maintain and protect historic architectural metal surfaces, features, materials and details through appropriate maintenance, cleaning and repair methods.

- ❑ Inspect architectural metal surfaces for evidence of moisture damage, corrosion, fatigue or structural failure and paint film deterioration.
- ❑ Provide adequate drainage of metal surfaces to avoid the collection of waste on horizontal surfaces and decorative elements. Clean metal roofs and gutter of debris and leaves.
- ❑ Maintain a protective, sound paint film or lacquer on ferrous metal surfaces. Repaint previously painted metal surfaces when needed in colors that are appropriate to the building or site feature. Clean and prepare metal surfaces for repainting with the gentlest, effective methods appropriate for the specific metal. It is not appropriate to use harsh abrasive techniques on historic metal features.

3. Repair historic metal features, materials, and surfaces using traditional preservation techniques, including patching splicing and reinforcing.

4. Replace deteriorated or damaged historic architectural metal features and materials, only if they are deteriorated beyond repair, in kind – matching the original in material, design, dimension and detail. Where possible, limit replacement to the deteriorated section only rather than the entire feature. Use compatible, substitute materials only if it is not technically feasible to replace in kind.

5. Replace a missing architectural metal feature with a new feature based upon accurate documentation of the original feature or a new design compatible in material, design, color, size and scale with the historic building or site. It is not appropriate to introduce a metal feature or detail to create a false historic appearance.



*Cast iron was a popular feature on commercial buildings of the late 19th century, as seen at 242 Guinn Street. This cast iron was produced by the Mesker Company of St. Louis and there may be other cast iron features hidden beneath added storefront materials in the downtown area.*



## Storefronts

---

Downtown Savannah has several buildings which display late-nineteenth or early-twentieth century storefronts. Visually, a streetscape is unified along a row of buildings by their respective storefronts, which share a common setback from the street and similar components. Storefronts consist of large display windows and a main entry. Besides display windows, functional and decorative features include doors, transoms, pilasters, awnings, entablatures, bulkhead panels and signs. Recessed entrances increase window display area. The floor area within the recessed entrance serves as an extension of the sidewalk and provides an additional surface for advertising such as the use of mosaic tile flooring. Materials for the bulkhead panels below the display windows include wood panels, ceramic tile, brick, marble or metal.

Regular care and maintenance for storefronts is important to the general appearance of the business and to the preservation of the building. Repair and replacement of damaged parts requires attention in matching the original in material, dimension, detail and color. Main wood components with caulking and paint to ensure a proper seal that prevents moisture from penetrating and causing deterioration. Masonry components of storefronts, such as brick and tile, may require re-pointing, as discussed under the guidelines for masonry. The loss of distinctive storefront features can detract from the historic character of the entire building. Likewise, the introduction of incongruous contemporary materials, such as vinyl or aluminum, for the traditional wood or tile diminishes the storefront's contribution to the character of the specific building and the surrounding area.

As time passed and styles changed in the 20th century, building owners often modified their storefronts in an effort to present a more modern image. Sometimes these changes become part of the historic fabric, such as adding Carrara glass to exterior surfaces. Where past alterations have resulted in the concealment of original features, such as transoms, bulkheads or display windows, owners are encouraged to remove these materials and restore the storefront's original appearance.

In most cases the HZC will normally require the following:

1. Retain and preserve historic storefronts, including their design, dimension, pattern, color, texture and detail, that



*This original storefront at 242 Guinn Street retains its frame bulkhead, four-light display window, transom and cast iron column.*

contribute to the overall character of a building, including their distinctive materials and features such as display windows, transoms, recessed entries, signs and bulkhead panels.

2. Maintain and protect historic storefront surfaces, materials, features and details through appropriate maintenance and repair methods for each material and finish as needed.

3. Repair historic storefront features, materials, and surfaces using traditional preservation techniques, including patching splicing and reinforcing.

4. Replace deteriorated or damaged historic storefront materials and features, only if deteriorated beyond repair, in-kind – matching the original in material, design, dimension, color and detail. Where possible, limit replacement to the deteriorated section only rather than the entire feature. Consider compatible substitute materials only if it is not technically feasible to replace in-kind. It is not appropriate to replace or cover over wooden storefront features with contemporary substitute materials such as vinyl, aluminum or masonite.

5. Replace a missing historic storefront feature or entire storefront with a new feature or storefront based upon accurate documentation of the original or a new design compatible in material, design, color, size and scale with the historic building. It is not appropriate to introduce a storefront feature or detail in an attempt to create a false historic appearance.

6. Install fabric awnings over storefronts, if desired and where historically appropriate, so that historic features are not damaged or obscured.

7. Storefront windows shall be as transparent as possible and any tinting shall not exceed 20% of visibility. If privacy is needed use curtains or blinds on the inside of the window.



*The marble paneled storefront at 430 Main Street (above) and Carrara glass storefront at 407 Main Street (below) are examples of modifications that are now historic in their own right and should be preserved.*



## Commercial Building Windows

---

Windows contribute significantly to a commercial building's appearance and may be indicative of architectural style periods. Functionally, these openings allow for natural light and ventilation. Aesthetically, their arrangement and configuration help define the building's historic character.

Negligence of historic windows can result in the loss of stylistic identity. Preserving original wood windows is always more desirable and more cost-effective than replacing them. Modern materials simply do not have the texture or impart the same historic feeling of original wood windows. Routine maintenance is easy and inexpensive. Broken sash cords can be replaced, and sashes that stick may be made operable as simply as moving the stop molding out a bit or scraping off excess paint. If the sash is too loose, the stop may need to be moved in slightly. Weatherstripping, re-glazing and caulking will help seal air leaks. Rotten or damaged wood can be preserved in place with a wood consolidant. Occasionally, a historic window sash may require replacement, but rarely, the entire window. Wood sash windows, like other historic wood elements, can be maintained and repaired with epoxy and paint for a proper seal to prevent deterioration from moisture.

When replacing window details such as casings or muntins, it is important to maintain the original character. The muntin profile of the new sash shall match the historic sash. If an original window is beyond repair, it is important that the replacement match the original in design, materials and dimensions. Never alter, add to, or diminish existing window openings on a historic building.

Traditionally, shutters were used to providing ventilation when it rained and protected closed windows during storms. Maintain and retain existing shutters, replacing them only if they are beyond repair. It is appropriate to reintroduce shutters only when there is clear evidence of earlier shutters. Adding retractable canvas awnings to upper floor windows is also appropriate and have been used for years, providing shade in warm weather and raising to allow the sun's heat to provide warmth in cooler weather.



*Retain original windows and transoms such as this one-over-one wood sash example at 416 Main Street.*



*Preserve features like the bay windows on the upper façade at 406-408 Main Street.*

In most cases the HZC will normally require the following:

1. Retain and preserve historic windows, including their dimensions, configuration, color, texture and detail, that contribute to the overall character of a building, including their functional and decorative features, such as sash, frames, surrounds, sills, shutters and hardware.
2. Maintain and protect the historic materials, surfaces, features, finishes and details of windows by appropriate maintenance and repair methods as needed. Repaint, as necessary, previously painted surfaces in colors that are appropriate to the building.
3. Repair deteriorated or damaged historic materials and features through traditional methods. It is not appropriate to remove a distinctive feature rather than repair it.
4. Replace deteriorated or damaged historic window features, only if deteriorated beyond repair, in-kind – matching the original in material, design, dimension and detail. Where possible, limit replacement to the deteriorated section only rather than the entire feature. Consider compatible substitute materials only if it is not technically feasible to replace in-kind. The HZC may request an expert opinion, provided by the applicant, for the necessity of window replacement.
5. Replace a missing window with a new window based upon accurate documentation if possible of the original or a new design compatible in material, design, dimension, color, size, scale, texture, profile, and detail with the historic building. It is not appropriate to introduce a new feature or detail that creates a false historic appearance.
6. New windows made of aluminum-clad wood with enameled finish may be appropriate as replacements for wood window. Thermal pane (also known as insulated glazing) replacement windows are acceptable only when the historic windows in a building have been previously removed. When used, thermal pane windows must have true divided lites. Insulated glass units have a finite life, requiring repeated replacement. A more sustainable option is single-glazed sash windows with storm windows.

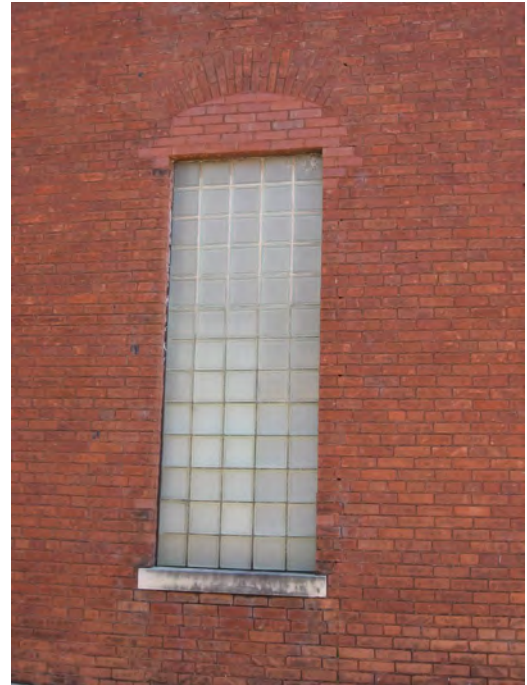

*This original window opening at 416 Main Street has been infilled with structural glass blocks. Restoration of the original window design in the future is encouraged.*



7. Vinyl is not an environmentally sustainable material and is not compatible with historic buildings. The installation of vinyl or vinyl-clad wood windows will not be approved in the historic district.

8. Install fabric awnings over windows, if desired and where historically appropriate, so that historic features are not damaged or obscured.

9. Replace missing or deteriorated wooden shutters with new shutters that are sized to fit the window opening and mounted to the window casing so they appear operable.

Note: For storm windows and doors see the Utilities & Energy Retrofit section.



*Vinyl-clad windows (above) and vinyl windows (below) are incompatible with the appearance of historic buildings and are not approvable in the historic district.*

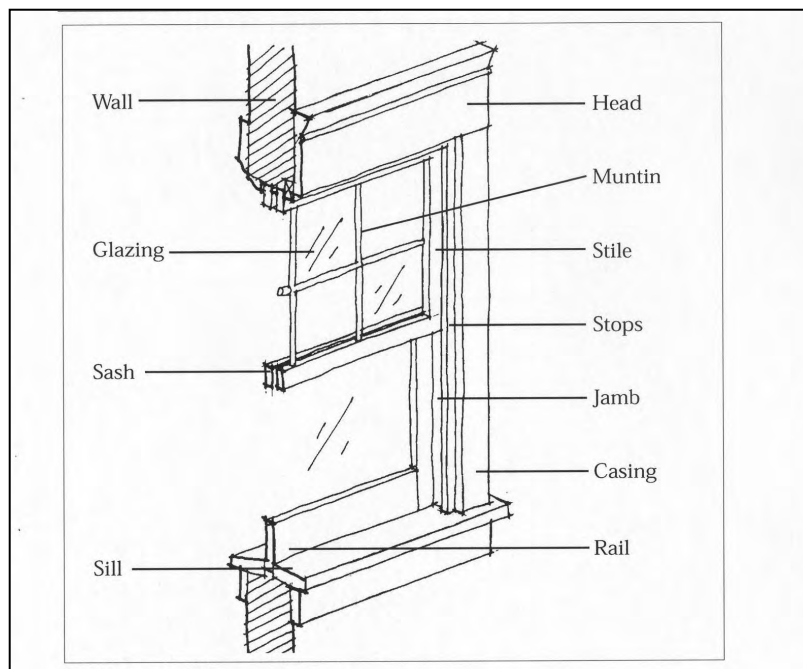

*This illustration shows the parts of a historic sash window.*



## Commercial Building Entrances and Doors

---

Entrances and doors are highly stylistic and individual to a commercial building's historic character and period. The main entrance of a commercial storefront is the focal point of a historic building entrance and a key architectural feature.

The loss and replacement of a historic building's door compromises integrity. Preserving the original entrance is always more desirable than replacing it. Routine maintenance is easy and inexpensive. Doors, because of their solid construction, can almost always be salvaged. Clean, repair, and maintain original wood; weatherstripping and good locks can make old doors energy efficient and secure. Replace the deteriorated bottom rail of a wood door rather than replacing the entire door. Wood epoxy can be used to maintain and repair original wood doors. Also retain original hardware such as hinges and handles. If an original door cannot be saved, it is important that the replacement match the original in design materials and dimensions.

In most cases the HZC will normally require the following:

1. Retain and preserve historic doors that contribute to the overall character of a building.
2. Maintain and protect the historic materials, surfaces, features, finishes and details of doors by appropriate maintenance and repair methods as needed. Repaint, as necessary, previously painted surfaces in colors that are appropriate to the building.
3. Repair deteriorated or damaged historic materials and features through traditional methods. It is not appropriate to remove a distinctive feature rather than repair it.
4. Replace deteriorated or damaged historic door features, only if deteriorated beyond repair, in-kind – matching the original in material, design, dimension and detail. Replace only deteriorated sections rather than the entire feature. Consider compatible substitute materials only if it is not technically feasible to replace in kind.



*An original single-light and panel door at 405 Main Street.*



*This entrance features a large transom as well as an original single-light glass and wood door (408 Main Street).*

5. Replace a missing door feature with a new feature based upon accurate documentation of the original feature or a new design compatible in material, design, dimension, color, size, scale, texture and detail with the historic building. It is not appropriate to introduce a new feature or detail that creates a false historic appearance.

6. If an entire door is missing, replace it with a design based either on accurate documentation of the original or on a new design compatible in material, dimension, color, size and scale with the historic building and district. For commercial buildings, single-light glass and wood doors with panels are most appropriate.

7. Install fabric awnings over door openings, if desired and where historically appropriate, so that historic features are not damaged or obscured.

8. Rear doors typically do not include glass panes, serving a solely utilitarian function. Since they are out of public view, it is not common for rear doors to require as rigorous a preservation approach. Replacement rear doors may be simple in design and fit the existing, unaltered opening.



*Original door at 407 Main Street.*

## Commercial Building Roofs

---

Roof shape and design are major features for historic buildings. Repetition of similar roof forms along a streetscape creates the sense of rhythm, scale, and cohesiveness. Roof pitch, materials, size, and orientation are all contributing factors to roof appearance. The most common roof forms for commercial buildings are flat or shed roofs, with gable and hipped forms being less common. Commercial roof features include parapets, cornices, and decorative finials and cresting.

In most cases the HZC will normally require the following:

1. Retain and preserve historic roof shapes, materials, and features. Preserve historic roofs in their original size, shape and pitch, and original features, such as cresting, finials, parapets, cornices, and chimney flues.
2. Maintain and protect the historic materials, surfaces, features, finishes and details of roofs by appropriate maintenance and repair methods. The prevention of moisture penetration is critical to roof maintenance.
  - Install and maintain gutters, downspouts, and splash blocks. Retain existing boxed gutters and keep them in good working order. Repair deteriorated gutters.
  - Locate downspouts away from architectural features and on the least public elevation of the building. Proper placement of downspouts will protect the building and not detract from its historic character.
3. Repair deteriorated or damaged historic materials and features through traditional methods.
4. Replace deteriorated or damaged historic roof features, only if beyond repair, in-kind. Match the original in material, design, dimension and detail. Replace only the deteriorated section rather than the entire feature. Consider compatible substitute materials only if it is not technically feasible to replace in-kind.
5. Do not introduce new roof elements that detract from the building's historic appearance and character. Install skylights, solar panels, decks, balconies, and satellite dishes behind a roofline parapet or to the rear of the roof.
6. Do not add roof features that are not original to the building, such as spires or parapets.



*Preserve distinctive roof features and materials, such as the slate roof at the Tennessee River Museum (above) and the pressed metal shingles on the tower of 416 Main Street (below).*

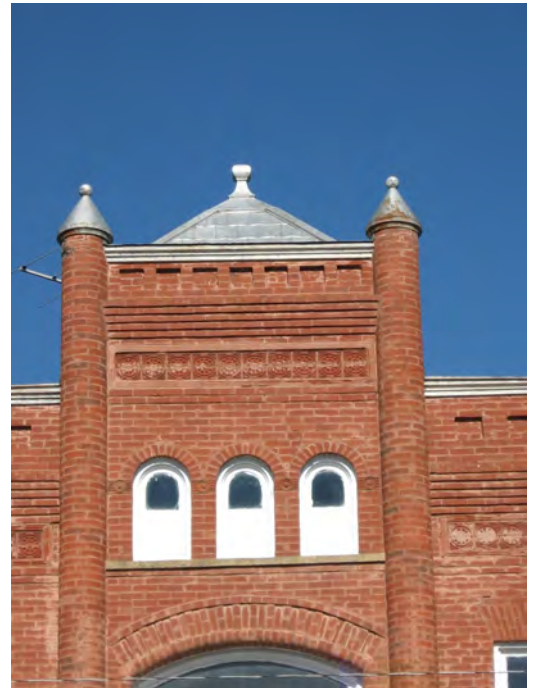

## Utilities & Energy Retrofit

---

Property owners are often concerned with energy conservation, adequate utility service and the upgrading or introduction of mechanical and communication systems. In historic districts, property owners must incorporate installations and practices that do not compromise the character of the buildings, the sites or the district as a whole.

Traditionally, commercial building design incorporated features such as awnings and transoms to deal with temperature and ventilation. Taking advantage of energy-efficient historic assets and responsibly retrofitting historic buildings can maximize their potential for energy conservation.

The first steps in retrofitting include the addition of adequate weatherstripping around window sashes and doors that prevent air leaks, and glazing that seals glass window panes. Once these repairs are made, storm windows and doors can be installed to provide a further barrier against the elements. The installation of exterior storm windows is encouraged in the historic district for commercial buildings. Old windows can far outlast new replacement windows. Retain original windows, and add storm windows to achieve energy savings equal to that most new replacement windows. Interior storm windows may also be an option but special care must be taken to ensure that moisture does not accumulate between the storm window and the original window, as this can cause damage to the wood surround. Both exterior and interior storm windows must be fitted properly and be operable in order to receive their maximum benefit.

To minimize the visual impact of exterior storm windows, choose a design with a narrow profile with painted or baked enamel finish in a color compatible with the sash color are appropriate. The meeting rails of operable storm windows for double-hung windows shall align with those of existing windows.

Carefully plan the introduction, rehabilitation or replacement of mechanical or communication systems such as heating and air conditioning units, solar collectors, fuel tanks, gas meters, television antennas or satellite dishes. Ensure their location and installation will not damage or detract from the historic character of the building, site, adjacent properties or the district as a



*Awnings are appropriate for commercial storefronts and entrances such as at 39 Court Street.*



*Retractable awnings assist in energy conservation for building owners and also protect pedestrians from the elements.*



*Storm windows are recommended to conserve energy.*

whole. Window air-conditioning units and solar panels are acceptable, but shall be located as unobtrusively as possible. Conformance with local building codes and utility company standards is required. New systems often require the installation of additional utility lines and poles. Avoid overpowering the streetscape with unsightly lines and poles. Investigate the use of underground cable to reduce visual detractions.

In most cases the HZC will normally require the following:

1. Retain and preserve the historic energy-conserving features and materials that contribute to the overall character of a building or site, including projecting front canopies, shutters, operable windows and transoms.
2. Protect and maintain historic energy-conserving features and materials using methods and treatments according to appropriate guidelines (i.e., wood, metal, etc.)
3. Repair historic energy-conserving features and materials using methods and treatments according to appropriate guidelines (i.e., wood, metal, etc.)
4. Replace missing historic energy-conserving features only if deteriorated beyond repair, in kind.
5. Increase the thermal efficiency of historic buildings through appropriate, traditional practices, including the installation of weatherstripping and caulking, storm windows and doors, insulation in attics, floors, and walls, and, if appropriate, awnings and operable shutters.
6. Install new mechanical systems, if needed, in areas and spaces that will require the least amount of alteration to the building exterior, historic building fabric and site features. On alley and rear elevations, screen them from view through fencing or lattice panels.
7. Select narrow-profile exterior storm windows, if desired, with meeting rails that align with the existing division of double-hung windows. Select storm windows with a painted or baked-enamel finish in a color compatible with the window sash color. Do not install storm windows with a bare metal finish.
8. Consider the installation of solar panels, placed where they are not readily visible from the street.



*The installation of solar panels on roofs of commercial buildings is appropriate and encouraged. These panels shall be sited below a building's parapet wall and not visible from the street as shown in this example.*



*Install HVAC units and store garbage receptacles behind commercial buildings, as in the 400 block of Main Street.*

9. Consider the use of reflective roofing surfaces to increase energy efficiency in warmer months. Most commercial buildings have flat roofs, and this retrofit would not be visible.

10. Install fabric awnings over storefront, window, and door openings, if desired and where historically appropriate, so that historic features are not damaged or obscured.

11. Locate new utilities and mechanical equipment, such as meters, exposed pipes, wires and heating and air-conditioning units, along the rear or side elevation not visible from the street. Screen them from view.

12. Mail boxes shall be located adjacent to entrances if using door mail slots is not an option.

13. Locate communication or mechanical items including satellite dishes, large antennas, roof ventilators, solar collectors and mechanical equipment so as not to damage or diminish character-defining roofs, on roof slopes that are not visible from the street or behind parapet walls.



*Heating and cooling units shall be sited at rooftops where they are not visible from the street (above) or are screened through landscaping or fencing (below).*

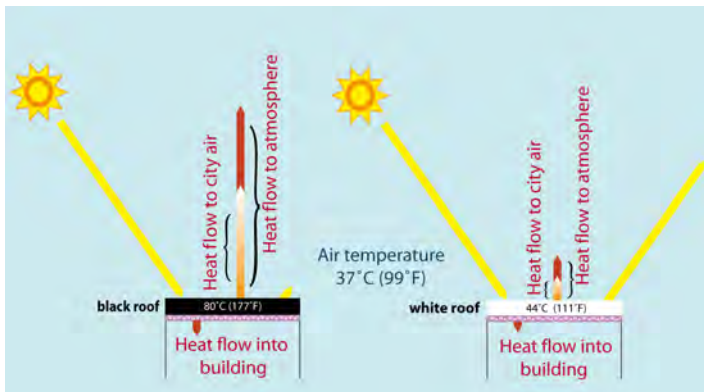

*Savannah's commercial buildings can be made more energy efficient through the introduction of reflective roofing materials as illustrated at left (Graphic courtesy Department of Energy).*

## Accessibility & Life Safety

---

Historic commercial buildings must be compliant with current standards for life safety and accessibility. The federal guidelines for the Americans with Disabilities Act of 1990 offer helpful flexibility in compliance for historic buildings. The HZC bases its review of such proposed alterations on whether the external modifications will compromise the architectural integrity of the building or the historic character of the building and site. Most building entrances in the downtown historic district have entrances which are of sufficient width to permit the passage of wheel chairs. If additional access is needed, owners are encouraged to contact the HZC staff early in the planning stages for professional assistance on such projects and to work with building code officials in investigating the most appropriate methods of meeting safety code requirements.

In most cases the HZC will normally require the following:

1. When considering a new use or change to a historic building, review all life safety code and accessibility requirements in deciding if the proposed change can be made without compromising the overall historic character of the historic building and its setting.
2. Accommodate life safety and accessibility requirements in ways that maintain and preserve the historic character of the building and its setting.
3. Introduce new or additional means of access, if needed, that are reversible and do not diminish the original design of a character-defining entrance or features such as porches. Consider secondary entrances for access.
4. Locate exterior fire stairs, fire doors or elevator additions on rear or inconspicuous side elevations. To diminish their impact, design these elements to be compatible with the architectural character, proportion, scale, materials and finish of the historic building.
5. Relocate incompatible existing fire stairs, when possible, to secondary locations such as rear elevations.



*Fire escapes and staircases are appropriately located on side or rear elevations (above, 390 Main Street).*

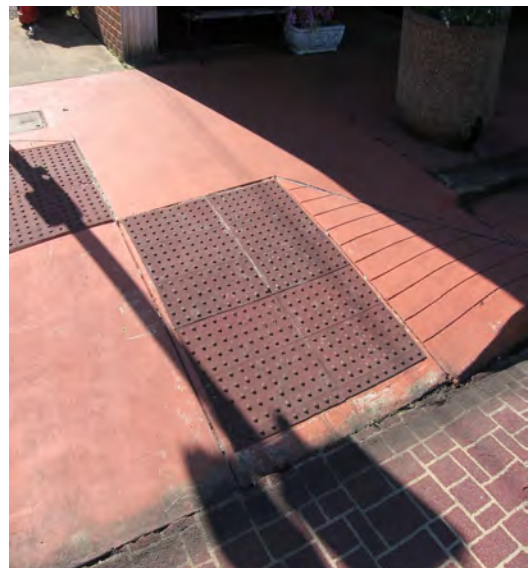

*The city has undertaken a number of ADA compliant efforts such as the sidewalk curbing along Main Street.*



## Parking Lots

---

Savannah's commercial area gradually accommodated the automobile by paving streets, installing parking spaces and constructing large off-street parking lots. Most parking lots are located behind the buildings on Main Street and Water Street. Several of these large parking lots lack any landscaping and striping and will require enhancement in the future.



*The large parking lots behind the north side of Main Street lack sufficient landscaping, striping and screening.*

Existing and future parking lots shall be screened with plants or fencing. Existing trees and their root areas shall be protected whenever possible with structural soils and permeable paving, and new trees planted to help with screening and also with glare, heat and noise. Incorporating planting medians or islands into large paved areas can further reduce their visual impact. Parking areas shall be paved with appropriate materials such as gravel, crushed stone, brick or asphalt.



*The addition of striping would assist in separating the parking spaces from pedestrian walkways.*

In most cases the HZC will normally require the following:

1. In the commercial historic district, parking lots shall be located behind historic buildings and out of pedestrian view. Creating parking areas in front of commercial buildings by removing sections of sidewalk is inappropriate.
2. Ideally, a parking lot will be shared by businesses or institutions with different peak use times. Side parking lots between businesses shall be screened with landscaping.
3. Clearly distinguish parking and pedestrian areas through landscaping such as fencing and plantings as well as striping.
4. Enhance and highlight the existing commercial parking lots with a unifying design and consistent landscaping.
5. The City of Savannah and property owners are encouraged to consider the installation of permeable paving surfaces in future parking lot additions or improvements.



*The City of Savannah should consider the use of permeable paving surfaces to allow for absorption of water and less run-off into storm sewers.*

## New Construction of Commercial Buildings

---

Savannah is fortunate in having solid blocks of buildings on Main Street with few vacant lots. However, buildings can be lost due to fires or natural disasters and new buildings may also be desired on side streets within the historic district. If designed appropriately, new buildings can be assets to a historic district, eliminating vacant lots and providing continuity to the streetscape. New building design shall not attempt to mimic historic building designs, but they shall adhere to established downtown design principles. Contemporary designs are acceptable if they are compatible with the overall character of the historic district. The compatibility of proposed new construction is considered in terms of both the building and the building site.

Any proposed new building shall be consistent with the setback, spacing between buildings, orientation to the street and lot coverage characteristic of the historic district. For a streetscape, a consistent setback – the distance from the front wall of the building to the street – maintains a rhythm of order and coherence. Similarly, a regular pattern of spacing between buildings contributes to the flow of a streetscape.

Compatibility of a proposed new building shall be viewed from an overall perspective, with consideration as to its scale, height, massing, proportion and roof form. These design aspects shall complement those of buildings surrounding a proposed site. Scale refers to the size of the construction units and their architectural details in relation to the size of a person. Height is also an important criterion in the district, as new buildings shall not extend substantially above over the historic streetscape.

Building features, openings, details, materials and textures characteristic of the downtown area provide additional criteria for evaluating the compatibility of proposed new construction. New commercial buildings shall heed traditional pedestrian orientation of the district and have storefronts or other compatible openings on the street level.



*New construction in the downtown area shall be compatible through the design of storefronts and upper façade detailing.*

*The new building shown above is contemporary in design but compatible with this historic downtown. The new building below has a recessed entrance and cornice line similar to traditional commercial designs.*



In most cases the HZC will normally require the following:

1. The siting of new construction shall be compatible with nearby historic buildings, following the unifying characteristics of the streetscape such as setback, spacing, orientation to the street and lot coverage.
2. Design the new construction so that the overall visual and physical character of the building site, including its topography and significant site features, is retained.
3. New construction shall be compatible with nearby historic buildings in terms of building scale, height, massing, proportion and roof form.
4. Design new construction to be compatible with nearby historic buildings that contribute to district character.
5. With respect to height-to-width ratios, design new buildings' windows and doors to be compatible with historic buildings that contribute to the district character.
6. Design new buildings with solid-to-void rhythms and open-to-solid proportions compatible with historic buildings that contribute to the overall district character.
7. Use materials and textures for new buildings in relation to the use of such materials and textures compatible with historic buildings and to the overall character of the district. Brick is the most appropriate material for new construction. Metal buildings may be constructed as long as they have a compatible brick façade on exposed elevations. The use of cementitious siding may be appropriate for rear elevations. Exterior insulation finishing system (EIFS) materials will not be allowed.
8. Select colors for a new building that complement existing use of color in the surrounding area.
9. New architectural details and articulation shall be compatible with historic buildings that contribute to the overall character of the district.
10. Windows shall be designed with divided lights and not have snap-in or flush muntin bars.



*New commercial buildings can be contemporary in design as shown above or mimic historic commercial buildings as shown below (65 Court Street). Either approach is appropriate as long as the new building is compatible with the adjacent historic buildings.*



---

## IV. Guidelines for Residential Buildings

---

### Savannah Historic District

---

The design guidelines for the Savannah Historic District are intended to provide property owners with guidance on appropriate rehabilitation and new construction. Listing in the National Register is an honorary distinction, and design review is not applied to the National Register listing. The residences in the Savannah Historic District are not within a local historic zone and are not subject to review by the Historic Zoning Commission. However, property owners are encouraged to follow these design guidelines in order to preserve and maintain the historic character of the district, enhance energy efficiency and construct compatible new buildings.

The Savannah Historic District is a National Register District with a period of significance from 1869 through 1958. Architectural styles within the district include Greek Revival, Queen Anne, Colonial Revival, and Craftsman designs, as well as a late Gothic Revival-style Church. As the county seat, Savannah was the historic center of commerce and politics, and the historic district was the residential neighborhood of the area's leading citizens. Early residents included the Walker, Williams, Irwin, Sevier, Churchwell, and Ross families.

The Savannah Historic District was originally listed in the National Register in 1980 with twenty-two properties. The district was listed as having significance at the local level in architecture, commerce, education, and politics/government. After two boundary increases during the 1990s, the Savannah Historic District now includes forty-two properties. The district's boundary is an irregular pattern along Main, Deford, Guinn, Church, College, Williams and Cook Streets.



*Most dwellings in the Savannah Historic District are of frame construction and reflect popular and vernacular building forms and styles of the late 19th and early 20th centuries (130 College Street).*

### Savannah Historic District Architectural Styles

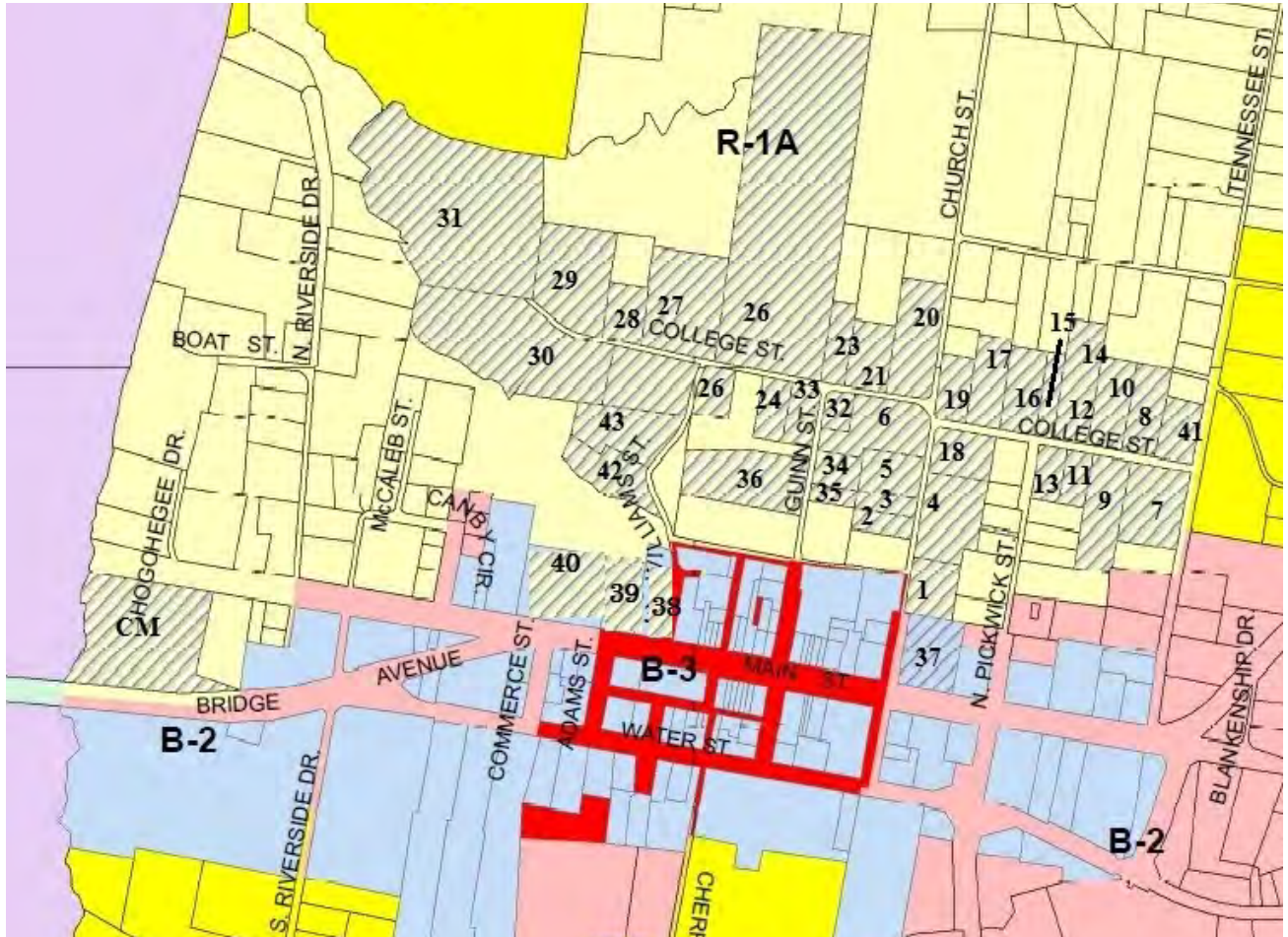

*The grey-shaded and striped parcels denote the location of the National Register-listed Savannah Historic District along College Street and adjacent streets and the individually listed Cherry Mansion on Main Street (CM).*

### **Greek Revival (1869-1880)**

With the notable exception of the Cherry Mansion, most of the oldest dwellings in Savannah were destroyed or damaged during the Civil War. The Williams-Churchwell House and the Johnson-Ledbetter House were both completed in 1869 to replace homes lost in the war. These dwellings were originally built in the Greek Revival style but remodeled into their present form at the turn of the 20th century. The Cherry Mansion also had its porches rebuilt in the early 20th century.

### **Queen Anne (1875-1915)**

Popular during the Victorian era, the Queen Anne style house is characterized by irregular shapes and a complex arrangement. The exterior of the house is often quite elaborate in its use of surface materials and detailing, and a complex color scheme further enhances the variety of materials used. Originally, body, trim, shutters and sash were each treated differently; and architectural details were emphasized with color. Surviving examples of the Queen Anne style in Savannah are simplified versions consisting of an asymmetrical mass covered with a hipped or gabled roof, with projecting wings and bays. They feature broad verandas that wrap around two and three sides of the house. Porches often feature intricately carved posts and railings, decorative trim commonly referred to as “gingerbread.”

The gable fields of many Queen Anne houses are covered with patterned wood shingles and sometimes a band of wood shingles separates the first and second stories. Wood clapboard is the most common siding material. Windows are tall and narrow, and patterns offer a clue to the period of construction. A two-over-two window sash division suggests a fairly early house, while one-over-one indicates a later structure. A trademark of the Queen Anne is a window with a border of small colored panes, surrounding a large pane. A small casement window of this design is sometimes found in gable end. Leaded and stained glass are often used in both windows and doors.



*The Williams-Riggan House at 170 College Street reflects the Queen Anne style, with its characteristic wrap-around porch, irregular roof, and wood trim details.*

### **Gothic Revival (1840-1910)**

The Gothic Revival style was popular for residential architecture through the mid- to late-nineteenth century. It persisted for church architecture well into the twentieth century in America. The style is characterized by its signature Gothic arch, which is pointed, rather than

rounded. The buildings of this style feature steep roofs. Houses of this style may have decorative vergeboard at the eaves. Gothic Revival designs were promoted in house plan books that embraced the picturesque ideal of new suburban settings. Its extended popularity for use in church buildings owes to its association with European religious architecture.

### **Colonial Revival and Neo-Classical Styles (1900-1930)**

The turn of the 20th century brought a revival of interest in many building styles of Europe and colonial America. Typically, early twentieth-century houses were distinguished by a general symmetry in the arrangement of their parts and restraint in ornamentation.

Colonial Revival style houses reflect the building traditions of late 18th and early 19th century colonial America. Windows in Colonial Revival style houses often feature multiple light divisions; shutters are common; and entrances feature paneled doors with sidelights and transom lights. Instead of a full front porch, there may be a front portico and a side porch with matching details

The Neo-Classical style emphasized classical forms-round porch columns, cornices with modillion blocks or detail molding and pediments. The Neo-Classical style employed the basic plan and details of the Colonial style but on a much larger scale and generally features two-story porticos on the main façade. These porticos most commonly featured Doric and Ionic columns.

### **Bungalow (1905-1930)**

The most common historic house style in Savannah is the Bungalow. This style originated in California in the early 1900s and spread eastward with the help of pattern books. The Bungalow garnered an enormous following because of its practical features. Bungalows could be sited on many urban lots of the period and was also used for rural dwellings.

Bungalows are generally single-story houses, although they can also be one and one-half stories. They feature gently sloping gable or hip roofs with wide overhanging eaves. Roof beams and rafters are almost always exposed. A common Bungalow form has the gable end facing the street, with the gabled porch roof set to one side. Occasionally, the roof will be brought forward to cover the front porch. Knee brace brackets supporting the roof are a common feature.



*The Gothic Revival-style First Presbyterian Church is located at 207 Tennessee Street at the east end of the historic district. It was built in 1903.*



*The dwelling at 320 College Street is a notable example of the Neo-Classical style and features a two-story portico with Ionic columns.*



*At 95 College Street, this Colonial Revival style dwelling from 1936 is distinguished by its symmetrical façade and pedimented entrance.*

Some Bungalows are more correctly labeled Craftsman houses, because they were influenced by the Arts and Crafts movement, which flourished in California in the early part of the twentieth century. The design philosophy accompanying this movement emphasized the relationship between manufactured structures and their natural surroundings. Craftsman houses are generally two-stories in height and constructed with natural materials such as native stone. Wood shingles, either left unpainted or stained a rich, dark color, were used for siding and roofs.



*This ca. 1919 Bungalow at 70 College Street displays a recessed porch and a gable dormer at the roofline.*

### **Ranch (1940-1970)**

In the mid-twentieth century, the Ranch style became popular across the nation. With servicemen returning from World War II, the demand for housing greatly expanded, and suburban tracts were developed on the periphery of cities and towns. Ranch style plans were designed with families in mind, opening the interior space and creating a more casual environment for family use. Ranch plans are typically rectangular in shape, with the long side oriented towards the street. This layout differed sharply from earlier traditional urban neighborhood planning when large yards were not common. Further, the wide porches of Queen Anne and Bungalow styles were eliminated in Ranch designs, as families gravitated to the back yard and patio for outdoor time. Ranch-style houses often feature large picture windows on the façade and oversized chimneys. These dwellings are frame in construction and may have brick veneer and other exterior masonry materials.



*Built in 1950, This dwelling is an example of the Ranch style with its wide, horizontal form, simple entry porch and large picture windows (125 Williams Street).*



---

# Residential Building Guidelines

---

## Windows & Doors

---

Windows and doors are important elements that help convey a building's historic character, expressing the architectural style and period. Functional as well as aesthetic, these openings allow natural light and fresh air into the building. The front door is the focal point of a historic building and a key architectural feature. Original doors are usually built of heavy wood and painted or stained a deep color for accentuation. Nineteenth and early-twentieth-century doors can have single, double or triple lights. Early- to mid-twentieth century doors may have multi-lights of equal size. Craftsman-style doors often feature nearly full-view glass with divisions of thin wood strips at the borders.

Similarly, window pane configuration can be indicative of style or period. Common nineteenth-century window designs were two-over-two or four-over-four wood-sash double-hung configuration. The trademark window of the Queen Anne style is a large pane bordered by small square panes of colored glass. One-over-one wood-sash windows became more common after 1900. The popular Queen Anne style of the Victorian period features tall, narrow windows that contribute to a strong vertical emphasis. Colonial Revival windows feature multiple-pane divisions often in a six-over-six or six-over-one pattern. The elegant Palladian window is a typical Colonial Revival element. Bungalows often feature long narrow panes in the upper sash and a single pane in the lower sash.

Insensitive treatment of the windows and doors of a historic structure can result in the loss of stylistic identity. Preserving the original feature is always more desirable and usually more cost-effective than replacing it. Routine maintenance and repair is usually easy and inexpensive. Broken sash cords can be replaced, and sticking sashes may be fixed by moving the stop molding out a bit or scraping off excess paint. If the sash is too loose, the stop may need to be moved in slightly. Weatherstripping, reglazing and caulking will help stop air leaks. Rotten or damaged wood can be preserved in place with a wood consolidant. When replacing window or door details, such as casings or muntins, take care to maintain the original character. Front doors, because of their solid construction,



*Original four-over-four wood sash windows at 370 College Street.*



*Original one-over-one wood sash window with decorative pedimented surround at 195 Williams Street.*

can almost always be salvaged. Clean, repair and maintain original hardware; weatherstripping and good locks can make old doors energy efficient and secure. If a window or door cannot be saved, it is important that the replacement match the original in design, materials and dimensions. Adding or changing existing window and door openings on a historic building shall be undertaken only as a last resort.

Traditionally, shutters were practical features, allowing for ventilation and protection of windows from the elements. Shutters also contribute to a building's aesthetics, and existing shutters shall be maintained and repaired as necessary. Adding new shutters where there is no evidence they were used in the past is discouraged. Only hinged, wood shutters are appropriate in the historic district, as are retractable canvas awnings. Fabric awnings provide shade while adding color. Solid-colored fabric awnings of blue, red, brown, green or tan are preferred for Colonial Revival dwellings. Striped awnings of the same colors are most appropriate on Bungalows and Queen Anne style houses.

(Note: For storm windows and doors see the Utilities & Energy Retrofit section.)

In most cases the HZC will normally require the following:

1. Retain and preserve historic windows and doors, including their dimensions, configuration, color, texture and detail, that contribute to the overall character of a building, including their functional and decorative features, such as sash, frames, surrounds, sills, sidelights, transoms, glazing, muntins, shutters and hardware.
2. Maintain and protect the historic surfaces, materials, features, finishes and details of windows and doors by appropriate maintenance and repair methods as needed. Repaint, as necessary, previously painted surfaces in colors that are appropriate to the building.
3. Repair deteriorated or damaged historic materials and features through traditional methods. It is not appropriate to remove a distinctive feature rather than repair it.
4. Replace in-kind deteriorated or damaged historic window or door materials and features, only if deteriorated beyond repair, matching the original in material, design, dimension and detail. Where possible, limit replacement to the deteriorated section only, rather



*Original six-over-one Craftsman style windows in the gable roof dormer at 70 College Street.*



*If replacement windows are necessary they **shall** have divided lights as shown above rather than applied muntin bars.*

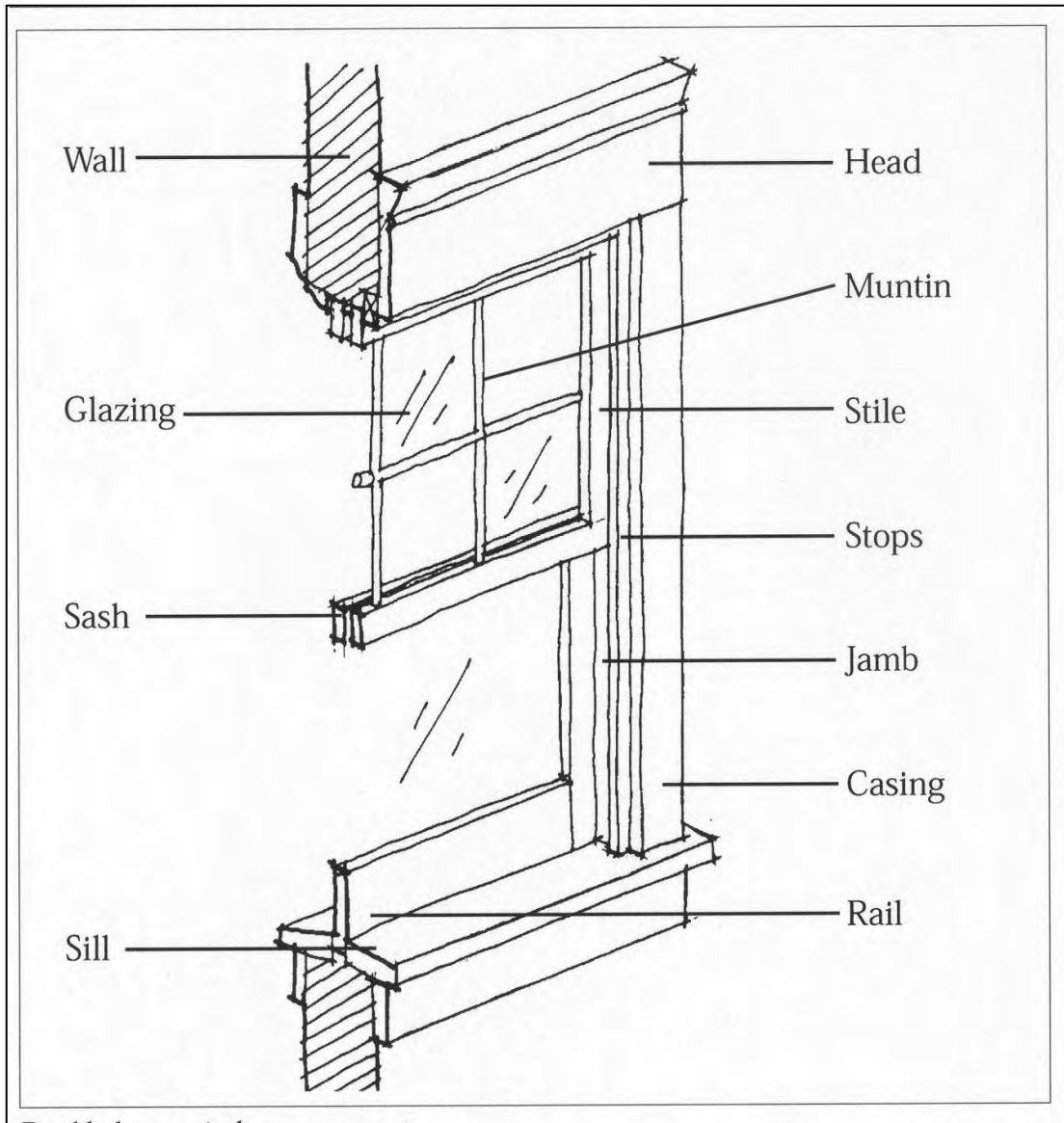

*This illustration defines the parts of a window.*

than the entire feature. Consider compatible substitute materials only if it is not feasible to replace in-kind.

5. In the case of a missing window or door feature, use existing documentation, such as an old photograph, to match the original, or use a new design compatible in material, design, dimension, color, size, scale, texture and detail with the historic building. Do not introduce a new feature that will result in a false historic appearance. Snap-in muntins are not appropriate replacements for true-divided light glazing.

6. It is not appropriate to install a new window or door opening or to cover or close an original opening on the primary façade of a historic building. If a new window or door is necessary, locate it only on a secondary elevation to diminish its visual impact.

7. Replacement shutters shall be made of wood and shall be sized to fit the window opening. If they are decorative and not functional, mount the shutters in the window casing so they appear operable.

8. New, aluminum-clad, wood windows with enameled finish may be appropriate replacements for historic wood. Thermal pane (also known as insulated glazing) windows are acceptable replacements only when the historic windows have been previously removed; they must have true divided lights. Insulated glass units have a finite life, requiring repeated replacement. A more sustainable option is single-glazed sash windows with storm sash.

9. Vinyl windows are aesthetically a poor substitute for original, wood windows. They have a short life-span and may need to be replaced again after ten years.



*Original paired three-light doors at 70 Pickwick Street.*



*The storm door installed at 215 Church Street is an appropriate design, allowing for full view of the dwelling's original single-light glass and wood door behind it.*

## Porches, Entrances & Balconies

---

Front porches, entrances and balconies help define the architectural character of a historic building. The various functional features of porches and entrances, including steps, handrails, balustrades, columns, pilasters, brackets, spandrels and roofs, enhance the overall appearance of the building, providing interesting detail. Originally, the front porch served to keep the entrance protected and provided a place to escape the summer heat. The front entrance and the balcony, together with the front porch, represent the important first view of the property and shall be preserved in their original state.

Among Savannah's historic district dwellings are several Bungalows, which feature a wide front porch. Turn-of-the-century Colonial Revival-style residences may feature a front portico or entry bay and a side porch with matching details instead of a full front porch. Nineteenth-century, Queen Anne-style residences display broad verandas that wrap around two or three sides of the house. Enclosing these open spaces is inappropriate, as the effect would drastically alter the historic character of the building. The enclosure of a side porch is discouraged but, because it is less prominent, might be appropriate for certain purposes – a sun porch, for example – if the building's architectural integrity is not compromised and the porch's identity is retained.

Because porches, entrances and balconies are highly visible focal points, routine care and maintenance is required. It is important to keep all wood surfaces painted to prevent damage from moisture. Porch floors were often built with a slight pitch for proper water drainage and this configuration shall be followed in porch floor replacement projects. When a porch, entrance or balcony – or any component or detail – is damaged beyond repair it is important that replacements match the original in material, texture dimension, design and color. If a porch, entrance or balcony is missing for some reason, it may be appropriate to construct an accurate reproduction of the original or a new design that is compatible with the character of the historic building and site.

In most cases the HZC will normally require the following:



*Queen Anne style houses often feature elaborate woodwork at porches (170 College Street).*

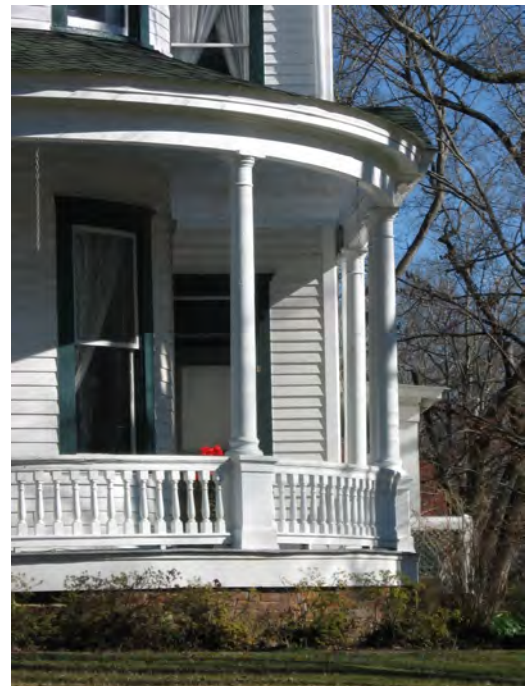

*Tuscan columns such as at 200 Church Street are used with several architectural styles, including Queen Anne and Colonial Revival.*

1. Retain and preserve historic porches, entrances and balconies, their historic materials and features, including their dimension, pattern, form, color, texture and detail, that contribute to the overall character of a building, including their functional and decorative features, such as columns, sidelights, balustrades, steps, floors and ceilings.

2. Maintain and protect the historic materials, surfaces, features, finishes and details of porches, entrances and balconies through appropriate maintenance and repair methods. Repaint, as necessary, previously painted features and surfaces in colors that are appropriate to the historic building.

3. Repair deteriorated or damaged historic materials and features through traditional methods. It is not appropriate to remove a distinctive porch, entrance or balcony feature, such as a bracket or railing, rather than repair it.

4. Replace deteriorated or damaged historic porch, entrance or balcony features, only if deteriorated beyond repair, in kind – matching the original in material, design, dimension and detail. Where possible, limit replacement to the deteriorated section only, rather than the entire feature. Consider compatible substitute materials only if it is not technically feasible to replace in kind.

5. Replace a missing porch, entrance or balcony feature with a new feature based upon accurate documentation of the original feature or a new design compatible in material, design, dimension, color, size, scale, texture and detail with the historic building. Do not introduce a new feature to create a false historic appearance.

6. If an entire porch, entrance or balcony is missing, replace it with a design based either on accurate documentation of the original or on a new design compatible in design, material, dimension, color, size and scale with the historic building and the historic district.

7. It is not appropriate to enclose a front porch or balcony. Consider enclosing a historic side or rear porch only if its form and architectural character are preserved.



*The fluted columns on the portico at 320 College Street feature Ionic capitals.*



*The original screened side porch on the dwelling at 95 College Street is an appropriate example for enclosed porches in the historic district.*

## Paint & Exterior Color

---

Color was an essential element of the original design intent of the architect or builder; however, the colors of most historic buildings have been changed over time and early black and white photographs can only offer a sense of the original tones and contrasts. For property owners interested in determining the color chronology of a specific building, examination of paint scrapings under a microscope by an architectural conservator can provide accurate information. Paint color selection may also refer to what palettes are appropriate to the architectural style and age of the building. For example, Queen Anne style houses were known for their flamboyant colors, whereas earthy and lighter tones were popular for Colonial Revival buildings. Applying appropriate colors can dramatically improve the overall appearance of a building. Property owners are encouraged to seek advice on appropriate paint colors from the HZC and knowledgeable professionals.

Several basic principles should be considered in choosing colors for historic buildings. Historically, trim work – such as corner boards, window and door casings, soffits and fascia – was often painted in a lower value or contrasting hue from the siding. Window sash and shutters were usually the darkest color on the building. Wood shingles were stained in dark colors; where wood shingles and clapboards were used in combination, the shingles were usually darker in value than the siding. It is also important to consider the compatibility of the roof color with nearby paint colors. Bright, garish colors are not appropriate for building exteriors in the historic district.

Beyond its decorative role, exterior paint is primarily a protective film allowing the building skin to shed water and slowing the weathering process. Cleaning painted surfaces will delay the need to repaint and thus slow the problematic build-up of paint layers. When repainting is needed, it is worth the effort to thoroughly prepare the surface in order to extend the life of the paint job. It is not necessary or desirable, however, to remove sound paint. If mildew is a problem, wash prepared surfaces with a mildew killer, rinse and allow to dry prior to repainting. Wood, exposed to the weather for long, may not hold paint and can be treated with a preservative before painting. Bare and chalky wood surfaces require an oil-base primer before the finish coats. Prompt application of a rust-inhibitive primer is necessary for bare ferrous metal



*Paint protects wood and highlights ornamental features (195 Williams Street).*



*Unpainted masonry walls **shall** be left unpainted unless the brick is badly damaged or has numerous repairs (First Presbyterian Church, 300 Tennessee Street).*

surfaces. Two finish coats of either latex or oil-based paint are usually adequate. Latex paint will not bond properly to old oil-based paint but may be applied over oil-based primer.

In most cases the HZC will normally require the following:

1. Retain and preserve historic painted surfaces and materials that contribute to the character of the building.

2. Maintain and protect historic painted materials and features through appropriate maintenance, cleaning and repainting methods as needed.

- ❑ Inspect painted surfaces for evidence of discoloration, moisture damage, and dirt buildup.
- ❑ Clean painted surfaces routinely to avoid unnecessary repainting, using the gentlest means possible.
- ❑ Ensure that surfaces to be repainted are clean and dry.
- ❑ Prime exposed metal and wood surfaces prior to repainting.

3. Repair historic painted surfaces and materials. Remove deteriorated and peeling paint films down to the first sound paint layer. Use the gentlest effective method for the specific material substrate. It is not appropriate to use destructive techniques that include power washing, sandblasting, high-pressure waterblasting or hazardous heating devices, such as butane or propane torches. Severely alligatored paint may need to be removed to the substrate.

4. Select paint colors appropriate to the historic building, site and district when repainting. Enhance the architectural style and features of a historic building through appropriate paint color sections and placement.

5. It is not appropriate to paint previously unpainted brick, stone, wood shingles and metals that were historically unpainted.

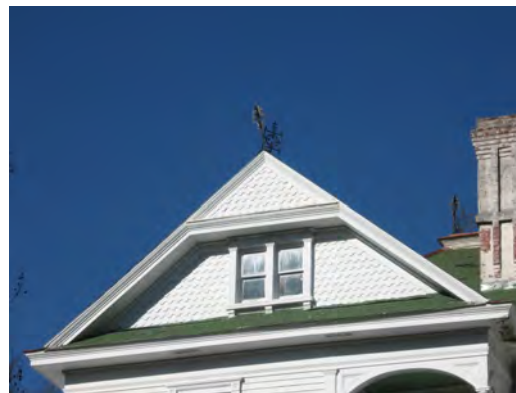

*Exterior wood siding requires thorough scraping and priming prior to painting (155 Williams Street).*

**RECOMMENDED COLOR CHOICES:**

*Frame Vernacular or Folk Victorian:* Contrasting wall and trim colors.

*Queen Anne:* Deep rich colors such as green, rust, red, or brown for walls and trim. Shingles may be differently colored than walls.

*Colonial Revival:* Softer colors for walls with white or ivory trim.

*Bungalow:* Earth tones, sometimes different colors for different floors, for walls and complementary trim.



## Roofs

---

Roof form and pitch are among the major character distinctions of historic buildings. Whether flat, shed, hipped, gabled or arranged in a combination of these forms, the roof is an essential element in the perception of the overall building. Pattern, scale, texture and color of roofing materials further define the character of the roof as do features such as chimneys, dormers, gables, gable vents, balustrades and turrets. The overall form of historic roofs and their historic features are important to preserve; consequently, it is generally not appropriate to alter the roof shape, eliminate significant features or add new features.

The most widely extant roofing materials in the National Register district are asphalt and fiberglass shingles which replaced earlier roof materials. Most original or historic roofing materials, including wood shingles, slate, and tile, are no longer extant in the district although there are some examples of original standing seam and pressed metal roofs.

The care and maintenance of the roof is critical to the preservation of a historic building. A leaky roof can compromise its structural integrity and accelerate the deterioration of a building's interior. Routine maintenance should include inspections twice a year to look for signs of deterioration: worn edges and ridges, bubbling of shingles, popped-up roofing nails and the accumulation of moss or debris on the roof surface. Another sign of asphalt or fiberglass shingle deterioration is the collection of mineral granules in the gutters. Metal roofs require inspection for watertight seams and a sound paint film. Life expectancy of metal roofing can be extended with the application of an elastomeric coating. This type of treatment is preferable to replacement, as prefabricated metal products for roofs often fail to copy the detailing of historic metal roofing.

Roof flashing provides watertight joints where roof planes change or protruding features such as chimneys, vents and dormers interrupt the roof surface. The source of most roof leaks is deteriorated or improperly installed flashing. Tar or roofing cement is an inappropriate substitute for properly installed flashing. The contemporary technique of weaving the shingles at roof valleys has a less attractive appearance and also deteriorates more rapidly than traditional metal flashing. Copper, galvanized sheet metal



*The dwelling at 130 College Street retains its original metal standing seam roof—these types of roofs should be repaired and retained.*



*The irregular roof plan and components are character-defining features at the Queen Anne-style dwelling at 200 Church Street.*

or aluminum with a baked enamel finish are more appropriate flashing choices in the district.

Gutters and downspouts shall be cleaned often and kept in good repair to facilitate roof drainage. Seamless gutters with baked enamel finish are an appropriate choice within the historic district when replacing damaged gutters or adding new ones. Built-in gutters shall be repaired rather than covered with new roofing materials. Downspouts shall empty away from the building to keep water away from the walls and foundation. Splash blocks, made of stone, concrete or slate, below downspouts can direct water away from the building if there is no below-grade foundation drainage system.

Reducing heat build-up on a roof will increase energy efficiency and may extend the life of roof shingles. One means of reducing roof heat is through the use of a powered ventilator; however, passive methods (e.g. shade trees) may perform equally at less cost. In the historic district, unobtrusive, low-profile ventilators shall be placed in inconspicuous locations like rear roof slopes to minimize their visibility. Existing wooden gable vents are historic features that shall not be concealed or replaced with metal vents.

A number of Savannah dwellings retain highly decorative brick chimneys. These feature fine craftsmanship in the corbelled brickwork at the top of the chimney. Historic chimneys shall be preserved, repointed as needed and maintained.

In most cases the HZC will normally require the following:

1. Retain and preserve historic roofs, their materials, dimension, pattern, form, color, texture and detail, that contribute to the overall character of the building, including their shape, line, pitch and overhang, as well as distinctive features and details, such as dormers, chimneys, concealed gutters, cornices, soffits, eaves and gable vents.
2. Maintain and protect historic roof materials, surfaces, features and details through appropriate maintenance and repair. Repaint previously painted metal roof features and surfaces in colors appropriate to the historic building.
3. Repair deteriorated or damaged historic roofs and roof materials and features through traditional methods. It is



*A number of dwellings retain original decorative corbelled brick chimneys such as at 155 Williams Street (above) and 215 Church Street (below).*



not appropriate to remove a distinctive roof feature, such as a chimney or dormer, rather than repair it.

4. Replace deteriorated or damaged roof materials and features, only if deteriorated beyond repair, in kind – matching the original in material, design, dimension and detail. Where possible, limit replacement to the deteriorated section only rather than the entire feature. Consider compatible substitute materials only if it is not technically feasible to replace in kind.

5. Replace a missing roof feature with a new feature based upon accurate documentation of the original feature or a new design compatible in material, design, color, size and scale with the historic building. It is not appropriate to introduce a roof feature or detail in an attempt to create a false historic appearance.

6. If the addition or replacement of gutters and downspouts is needed, install them with care so that no distinctive building features or details are concealed, diminished or lost. Except if they are copper, select new gutters and downspouts that are painted or finished in an appropriate color. Replace in kind distinctive half-round gutters and cylindrical downspouts.

7. Introduce contemporary roof features, such as skylights, vents, solar collectors and large antennas, only if they can be located so that they do not diminish the overall character of the historic roof and building. Select locations on secondary elevations out of view from the street.



*Example of an appropriate gutter and downspout.*



*New metal roofs shall match historic profiles of crimping and spacing to match original metal roof designs of the dwelling's period.*

## Wood

---

Wood, the most prevalent building material in the Savannah Historic District, can be fashioned into a myriad of features and decorative details. Wood clapboard – beveled boards that are thicker at the bottom edge and applied so they overlap by an inch or so – is the most common siding material in the district. Other historic wood siding types, including drop siding, flush siding and board-and-batten, as well as wood shingles, are also found on houses in the historic district.

Wood siding and features shall be systematically maintained and repaired in order to enhance their inherent qualities. A regular maintenance program includes caulking and sealing vertical and exposed wood joints to prevent the entry of water beneath the wood surface; painting to protect the surface from deterioration due to light and moisture; and carpentry to repair or replace decaying boards and other wooden elements through splicing or piecing. Take care to select replacement wood that matches the design and dimensions of the original. Wood consolidants or epoxies that stabilize and save a damaged or decayed feature in place may be the best solution for preserving difficult-to-replicate, distinctive features.

Since water and ultraviolet sunlight are two key factors in the deterioration of wood surfaces, protecting these surfaces with a sound paint film or stain coating is critical in extending their useful life. The application of chemical wood preservatives or the use of pressure-treated wood – wood treated with chemicals during manufacture – can also lengthen the life of wooden surfaces or features. It shall be noted, however, that while a vertical application of pressure-treated wood, such as for siding, trim, and door and window sills, horizontal applications tend to warp and can be difficult to paint.

Wood is a relatively soft material and it requires appropriately gentle cleaning techniques in preparing for repainting. Often low-pressure washing with mild household detergents, to which an anti-mildew solution can be added, is adequate for wood surfaces with intact paint films. Selectively hand scraping and sanding of the surface after washing is usually needed as well. If paint layers are peeling, alligatored, or deteriorated, the careful use of paint-removing devices, such as electric heat plates, infrared, hand-scraping, and hot air guns, may be



*Wood architectural elements, including porch posts and railing, are important to a dwelling's historical appearance and shall be maintained (70 College Street).*



*Retain and do not conceal original wood features such as the shingles in the gable field at 155 William Street.*

necessary. Permanent damage to the wood surface can result from the use of harsher techniques such as sandblasting, high-pressure waterblasting, the application of harsh alkaline strippers or the use of propane and butane torches. These techniques are not appropriate on historic wood surfaces.

The substitution of artificial siding, such as aluminum or vinyl, is not appropriate in the historic district. Such materials can hide signs of damage or decay; trap moisture in the space created next to the wood of the house; destroy historic materials with an abundance of nail holes; and, in concealing the historic fabric, compromise the character of the building and the district as a whole. Substitute sidings lack the warmth and charm of wood since they do not provide the same dimension, shape, texture, scale and detail as wood and, from an energy conservation standpoint, they are not good insulators. Also, artificial siding will eventually require painting, which is a primary reason homeowners conceal their wood siding. Removal of artificial siding and restoration of the original wood siding can result in a dramatically positive change in the building's appearance and is strongly encouraged.

In most cases the HZC will normally require the following:

1. Retain and preserve historic wood materials and features, including their color, dimension, texture, pattern, form and detail. that contribute to the overall character of a building, site or district, including siding, exterior trim, columns, cornices, balustrades, architraves, porches windows and doors.

2. Maintain and protect historic wood surfaces, materials, features and details through appropriate maintenance, cleaning and repair methods as needed.

- ❑ Inspect exterior wood surfaces for evidence of moisture damage, mildew and fungal or insect infestation.
- ❑ Provide adequate drainage of wood surfaces to avoid the collection of water on horizontal surfaces and decorative elements. Caulk or seal vertical and exposed wood joints to avoid moisture penetration.
- ❑ Maintain a protective, sound paint or stain film on exterior wood features. Repaint previously painted wood surfaces when needed in colors that are appropriate to the building or site feature. (see "Paint & Exterior Color" section for color scheme recommendations). Clean and prepare wood



*Preserve and maintain original wood siding through proper painting and regular maintenance (140 College Street).*

surfaces for repainting, using the gentlest effective methods, such as low-pressure washing, hand scraping and sanding. It is not appropriate to use destructive techniques that include power washing, sandblasting, high-pressure waterblasting (greater than 300 psi), chemical strippers, or hazardous heating devices, such as butane or propane torches.

3. Repair historic wood features and materials using traditional preservation techniques, including patching, splicing, reinforcing and consolidating.

4. Replace historic deteriorated or damaged wood features and materials, only if deteriorated beyond repair, in kind – matching the original in material, design, dimension and detail. Where possible, limit replacement to the deteriorated section only rather than the entire feature. Consider compatible substitute materials such as cementitious siding only if it is not technically feasible to replace in kind. It is not appropriate to cover or replace historic wooden features such as siding with inappropriate substitute materials such as vinyl, aluminum or masonite.

5. Replace a missing wood feature with a new feature based upon accurate documentation of the original feature or a new design compatible in material, design, color, size and scale with the historic building or site. It is not appropriate to introduce a wood feature or detail in an attempt to create a false historic appearance.



*The application of vinyl siding often involves the removal of original historic features and can cause condensation in the walls.*



*The use of cementitious siding may be appropriate for new construction, repairs on garages and repairs on the rear elevations of dwellings. This kind of alternative siding is not appropriate on elevations of a historic building that are visible from the street.*

## Masonry

---

Most dwellings in Savannah's residential historic district are of frame construction, but many have masonry elements such as foundations, porch columns and chimneys. Masonry materials includes brick, native stone, terra cotta, slate, tile, concrete block and stucco. The texture, scale, color, bonding pattern, joints and details of masonry surfaces all contribute to the general character of historic building and provide a source of permanent beauty. Brick is by far the most common masonry materials found in the Savannah Historic District.

Original chimneys are significant features of Savannah's historic houses. In the historic district of Savannah there are many brick chimneys, several with decorative corbelling patterns, making them functional and decorative architectural features. Preservation of these chimneys provides both aesthetic and safety benefits.

Masonry foundations can also be found in the Savannah Historic District. Some foundations have been painted and many are screened by plantings. It is not uncommon for foundation cracks to occur as houses settle. Severe problems, such as large cracks that go through the masonry, bulging or sagging walls, unlevel bricks from one corner to the next and sagging interior floors and walls may require the consultation of a mason or structural engineer with preservation experience. When entire sections of masonry units are damaged or missing, it is important to match replacements to the original as closely as possible in material, color, design and dimension. Replacement in kind is not usually a problem.

Masonry surfaces are quite durable and require minimal maintenance. Recommendations for cleaning and repointing are addressed in the commercial section of the guidelines.

In most cases the HZC will normally require the following:



*Brick foundations shall be repointed with brick and mortar to match the original.*



*Keep masonry surfaces such as exterior walls and chimneys in good repair (250 College Street).*

1. Retain and preserve historic masonry materials and features, including their color, texture, pattern, form and detail, that contribute to the overall character of a building, site or district, including chimneys, foundations, walls, roofs, steps, retaining walls, walkways and terraces.

2. Maintain and protect historic masonry materials, surfaces, features and details through appropriate maintenance, cleaning and repair methods as needed.

3. Repair historic masonry mortar joints by repointing them if the mortar is deteriorated or missing, or if there is evidence of moisture penetration. Remove loose and deteriorated mortar with care using hand tools prior to repointing. The new mortar shall match the original in color, composition, strength and texture, duplicating the appearance of the original mortar joint. If possible, avoid masonry coatings and water repellents unless traditional repointing and repair techniques are not successful.

4. Replace historic deteriorated or damaged masonry materials and features, only if deteriorated beyond repair, in kind – matching the original in material, design, dimension and detail. Where possible, limit replacement to the deteriorated section only, rather than the entire feature. Consider compatible substitute materials only if it is not technically feasible to replace in kind.

5. It may be appropriate to replace a missing masonry feature with a new feature based upon accurate documentation or a new design compatible in material, design, color, size and scale with the historic building or site. It is not appropriate to introduce masonry features that will create a misleading historic appearance.



*The use of brick veneer was widely used as an exterior material for post-World War II Ranch style dwellings (113 Main Street).*



## Exterior Lighting

---

Electric lights for the exteriors of dwellings were not common until the early twentieth-century. When fixtures were installed, they were generally small hanging pendants or projecting metal fixtures placed near the entrance. Today, owners of historic residences can install fixtures of similar, modest design that enhance the character of the Savannah Historic District.

If original lighting fixtures exist they shall be retained, repaired as needed and preserved. If original fixtures are missing or damaged, appropriate replacements can be selected which are appropriate to the design of the house. Alternatively, contemporary designs that complement the building can be installed.

When installing exterior lighting for safety and security, it is important not to detract from the style and character of the building and site. It is also important that any exterior lighting not compromise the character of adjacent properties. During the selection of compatible lighting fixtures, attention shall be given to location, design, material, size, scale, color and brightness. Warm-spectrum light sources, yellow-tone glows, and unobtrusive fixtures are recommended. Timers that shut off lights when they are not needed in order to save energy and minimize their excessive intrusion might be considered.

In most cases the HZC will normally require the following:

1. Retain and preserve historic exterior lighting fixtures and materials that contribute to the overall character of a building, site or district, including their functional and decorative elements and details.
2. Protect and maintain historic light fixtures through appropriate maintenance, cleaning and repair methods as needed.
3. Repair historic light features, materials, and surfaces using traditional preservation techniques for metal or wood, accordingly.
4. Historic exterior lights that are missing or too deteriorated to be repaired can be replaced with a fixture that is either similar in appearance, material, detail and scale to the original or is compatible in design, scale, materials and color with the building and streetscape.



*Preserve and maintain original light fixtures or those added in the early 20th century such as the fixture at 95 College Street.*



*Replacement light fixtures shall be in keeping with the period of the house such as this Craftsman light fixture on a Bungalow style dwelling.*

5. New exterior lighting shall be compatible in design with the character of the building, site or district. Consider the appearance, location, material, color, scale, finish and lighting brightness of lighting options. It is not appropriate to introduce new lighting that compromises the overall historic character of the building, site or district. It is not appropriate to create a false historical appearance through the installation of anachronistic styles of lighting fixtures.

6. Introduce new light fixtures in locations that complement the overall historic character of the building, site or district. In considering a proposed location, review the height, color, direction and brightness of the lighting source. It is not appropriate to over-illuminate or indiscriminately light a historic building, site or streetscape. Use lighting to accent an entrance as well as provide security.

7. Introduce lighting for safety and security in locations and ways that are consistent with the historic character of the building, site or streetscape. Consider low-level lighting sources for safety and security needs for residential locations-where it is not appropriate to install security lights mounted at standard heights on utility poles. When needed, introduce recessed lighting, footlights, post-mounted lights or directional lights in unobtrusive locations that do not diminish the overall historic character of the historic building, site or streetscape.

8. Footlights shall be spaced at regular intervals that provide sufficient lighting for safety yet not detract from the historic building.

9. Ensure that lighting does not spill onto adjacent properties.



*The use of solar powered footlights along walkways is an appropriate method for exterior lighting as shown above and below.*



## Fences & Walls

---

Fences and walls are significant features of the landscape that served functional and aesthetic purposes. There are several original fences of wrought iron as well as stone walls in Savannah's historic district. Painted wooden picket fences with gates were most common at the turn of the century. The pickets were usually thirty-six inches high with posts about six inches higher. In Savannah, brick or stone retaining walls were often used to maintain the grade of the front yard. Privacy fences are often used in rear side yards and backyards to provide visual screening of informal yard areas from public view. These utilitarian fences are generally built of solid wood.



*Retain original metal fencing like this hoop and dart fence at 15 College Street*

It is important to maintain existing fences and walls and to ensure new ones are compatible with traditional design. The longevity of wooden and iron fences can be extended if the bottom level of the fence is raised slightly above the grade in order to avoid deterioration from ground moisture. Also, wood fences can be painted for additional protection. Singular deteriorated pickets or boards shall be replaced with ones of pressure-treated wood. They shall be properly seasoned for the adherence of paint. Pickets are typically stained, painted white or painted a trim color that complements the house.



*It is important to preserve and maintain original retaining walls of stone, brick or rock-faced concrete block such as this wall at 155 Williams Street.*

To discourage rust and corrosion of iron fences, remove loose paint and rust with a wire brush and apply immediately with an appropriate metal primer. Iron fences shall then be painted in a traditional dark green, black or brown. It shall be noted that cast iron and wrought iron fences can be reproduced. If replacement is necessary, a variety of traditional iron fencing is manufactured today. Brick and stone walls shall be repaired and maintained in similar fashion as exterior building walls. The guidelines for masonry provide additional information.

New front-yard fences are generally not encouraged in the district, since they were not typically employed in the early part of the century. However, in rear yards, simple picket fences, woven wire fencing and solid privacy fences constructed of vertical wooden uprights may all be considered. Incompatible contemporary materials such as vinyl or metal chain link fencing and imitation masonry are not appropriate fence and wall materials to consider for district locations that are visible from the street. Aluminum security fencing has become a popular option

for back yards. Aluminum fences are often more contemporary in style and therefore are not an appropriate substitute for wrought iron fencing traditionally located at front lot lines. Vinyl fences are also discouraged for front yards.

In most cases the HZC will normally require the following:

1. Retain and preserve historic fences and walls, their materials and features, including stone, brick, wood and cast iron. that contribute to the overall character of a building, site or district, including the functional and decorative elements and details of fences and walls such as gates, pickets, pillars and posts. It is not appropriate to cover or replace historic wall or fence materials with contemporary coatings or substitute materials.

2. Maintain the historic masonry, wooden or metal elements of fences and walls through appropriate methods for the material.

3. Repair historic fences and walls, as necessary, through traditional repair methods for metal, wood, or masonry, accordingly.

4. Replace damaged sections of historic fences and walls only if deteriorated beyond repair, in kind to match the original in material, size, shape, dimension, pattern, texture, color and detail. Where possible, replace only the damaged or deteriorated portions rather than the entire feature. It is not appropriate to replace historic wall or fence materials with incompatible contemporary substitute materials such as artificial siding, plastic panels, landscape timbers, railroad ties, corrugated metal and vinyl or metal chain link fencing.

5. If a historic fence or wall is missing or severely damaged, it may be appropriate to replace it completely. The new fence or wall shall be based upon accurate documentation of the historic one or on a new design compatible with the historic character of the building or the historic district.

6. Repaint previously painted or stained fences and walls in colors that are appropriate to the historic building or site.

7. Construct new fences and walls, if necessary, in traditional materials in locations and configurations characteristic of the district. Ensure the height of new



*Historic designs are most appropriate for new wood picket fences such as the fence at 210 College Street.*



*Privacy fences are appropriate for rear yards as long as they are set back from the front of the house (150 College Street).*

fences and walls are consistent with the height of historic fences and walls in the district.

8. Privacy and security fences shall be limited to rear yards and side yard locations beyond the mid-point of the building. The structural members of the fence shall be on the inside of the fence as not to be visible to public view. It is not appropriate to replace historic wall or fence materials with incompatible contemporary substitute materials such as artificial siding, plastic panels, landscape timbers, railroad ties, corrugated metal and vinyl or metal chain link fencing.

9. Vinyl and metal chain link fences are not appropriate in front yards or other locations where they are visible from the public-right-of-way, as they detract from the character of the historic district and are incompatible landscape features. Where possible, screen existing chain link fences with vegetation such as ivy, climbing roses, wisteria, evergreens and shrubs.



*Privacy fences are appropriate on rear or side elevations, not in view from the street (110 College Street).*

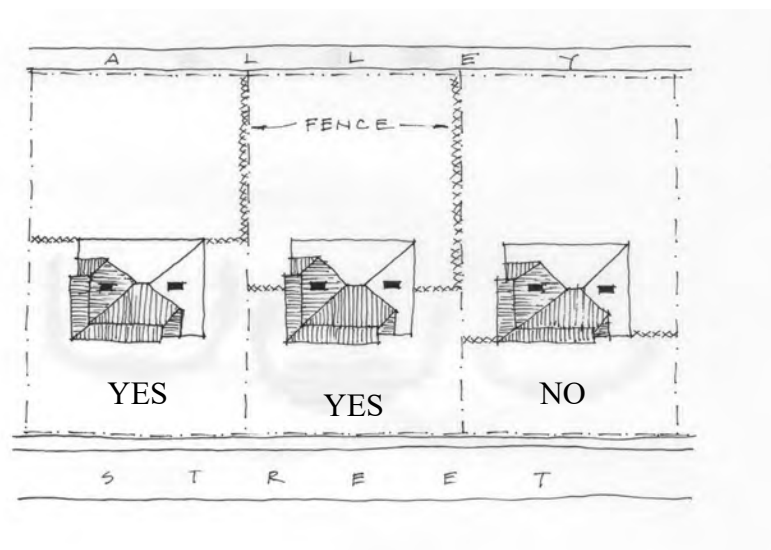

*Privacy fences shall be recessed back from the front wall so as to not obscure important features of the dwelling.*

## Walkways, Driveways & Off-street Parking

---

Walkways, driveways and off-street parking areas may not seem obviously significant features, yet their placement defines human movement within a historic district and their design and materials add texture to the historic district as a whole. The streetscape of a historic district retains its unity when walkways and driveways are designed and built of similar materials and with consistent spacing and placement.

In the Savannah Historic District, most residences feature straight walkways of concrete or brick that lead directly from the public sidewalk to the front door of the dwelling. Steps are incorporated depending on the topography of the front yard. As the district predated the introduction of the automobile, some dwellings do not have driveways at all. Most driveways are narrow, but are as wide as was needed to accommodate the average size of earlier automobiles. The first paved driveways consisted of two concrete parallel runners with grass in between. Although many of the original runners have been paved over, parallel runners can still be an attractive driveway treatment.

Necessitated by the widespread use of the automobile, off-street parking areas can have a significant impact on the character of a historic district. When located as inconspicuously as possible and buffered appropriately through the use of plant and fence screening, new parking areas can often be successfully blended into a sensitive historic environment. Existing trees and their root areas shall be protected whenever possible. Planting new trees helps to reduce glare, heat and noise. Incorporating planting medians or islands into large paved areas can further reduce the visual impact of parking areas. The use of structural soil can counter the common problem of lack of soil in paved areas. This is a relatively new material consisting of angular gravel, clay-loam soil, and a binding gel; once installed, structural soil allows for root growth beneath the top pavement surface. Parking areas shall be paved with appropriate materials such as gravel, crushed stone, brick or asphalt.

In most cases the HZC will normally require the following:



*Retain and maintain original brick and concrete walkways such as at 170 College Street, above, and 130 College Street, below.*



1. Retain and preserve historic materials, features and details of traditional walkways and driveways, including their configurations, materials, topography, dimensions and details, that contribute to the district.

2. Maintain historic walkways, driveways and off-street parking areas and their features.

3. Repair historic walkways and driveways as necessary through traditional repair methods for masonry.

4. Replace damaged or deteriorated sections of historic walkways, driveways and off-street parking areas, only if too deteriorated for repair, in kind – matching the design, material, dimension, color and texture of the feature.

5. Replace a severely deteriorated or missing historic walkway, driveway or off-street parking area, only if deteriorated beyond repair, with a new feature based upon accurate documentation of the original or a new design compatible in location, dimension, material and color.

6. Introduce new walkways, driveways and off-street parking areas, if needed, to be compatible in configuration, location, dimension, material and color with existing walkways, driveways and off-street parking areas that contribute to the character of the district.

7. Design new walkways, driveways and off-street parking areas so that the site topography and significant site features, such as mature trees, are retained. If these features are to be added within the drip zone area of mature trees, consult a professional arborist to ensure the long-term health of a tree(s) when working within the drip zone. Protect archaeological resources and significant site features during and after construction by limiting site disturbances and changes in grade.

8. For sites that are residential in character, locate off-street parking areas in inconspicuous rear yard locations not visible from the street. Screen and buffer off-street parking areas with landscaping, or fences. Diminish the impact of large parking areas with planting islands that subdivide the paved areas.



*Brick patterns of original sidewalks shall be preserved and maintained (120 Main Street).*

## Garages & Accessory Structures

---

The historic garages, storage buildings and sheds still in existence in the historic district contribute to the character of the individual site and the overall district. The private garage, evolving from the carriage house and horse barn of the nineteenth century, was modified in the early 1900's to store an automobile. The earliest garage was a simple frame structure with no floor, which could accommodate a single car. Gradually, garages became more substantial structures and sometimes provided living quarters for household help. Most early garages were single-bay structures made of wood, located in the rear yard, often at the end of the driveway. Smaller accessory structures were located in the rear yard as well and generally were not visible from the street. Sometimes these structures reflected the style, materials and details of the principal site structure.

An important feature of the garage design was and is the door, which expresses function and defines age and style. Early wooden doors featured glass panels. Multi-car garages featured identical doors placed side by side. Door types included hinged, roll-up, sliding and folding accordion doors, or a combination of these. Typically, doors were paneled, regardless of the opening device.

Preservation of early garages and accessory structures requires regular maintenance and repair. It is common to find that early outbuilding structures were built directly on the ground, which will lead to deterioration and potential loss of the structure. The sill can be replaced if deteriorated, while still preserving the building. A historic accessory building may be placed on a new, low foundation or piers to prevent future deterioration. The introduction of a new garage or accessory building shall echo distinctive features, such as roofline and materials, of the principal structure.

In most cases the HZC will normally require the following:



*Historic wood frame outbuildings such as at 215 Church Street remain extant and are important resources of the property.*



*Preserve and maintain historic garage buildings from the early 20th century (200 Church Street, above, and 130 Church Street, below).*





1. Retain and preserve historic garages and accessory structures, their character-defining materials, features and details, including their roof forms, doors, walls, foundations and architectural trim, that contribute to the overall character of the building site or historic district.

2. Maintain and protect historic garages and accessory structures and their materials.

3. Repair historic garages and accessory structures and their materials, as necessary, through traditional methods.

4. Replace damaged or deteriorated sections of historic garages and accessory structures, only if deteriorated beyond repair, in kind to match the original in material, size, shape, dimension, pattern, texture, color and detail. Where possible, replace only the damaged or deteriorated portions rather than the entire feature. If only the sill of the building is deteriorated, replace only that portion and raise the building to place it on a new foundation.



5. Replace a severely deteriorated or missing historic garage or accessory structure with a new structure based upon accurate documentation of the original feature or a new design compatible in form, roofline, height, materials, size, scale and finish with the main building or with other garages or accessory structures in the district.

*If new garage doors are needed, they shall be of paneled wood design similar as those on the new garage at 520 Main Street.*

6. Introduce new garages and accessory structures in locations that are compatible in orientation and placement with the historical relationship of garages and accessory structures to the main building and the site in the historic district. It is not appropriate to introduce a new garage or accessory structure if it will detract from the overall historic character of the main building or the site. New garages or carports shall be sited where they are not readily visible from the street or public right-of-ways.



7. Introduce a prefabricated accessory building only if it is compatible in form, roofline, materials, size, scale and finish with the main building or other traditional accessory buildings in the historic district. It is not appropriate to introduce metal accessory structures in the historic district unless they are sited at locations not readily visible.

*New garage doors shall not be of solid aluminum or steel design unless the garage is not readily visible from the street.*

## Utilities & Energy Retrofit

---

Property owners everywhere today are concerned with energy conservation, adequate utility service and the upgrading or introduction of mechanical and communication systems. It is important in historic districts that such concerns be addressed in ways that do not compromise the character of the buildings, the sites or the district as a whole.

In the Savannah Historic District there is evidence of energy efficiency that is testimony to the wisdom of an earlier era. Shade trees provide a natural awning for residences and streets. Extended porches and plantings provide shaded outdoor space and protect interiors from the heat of the summer sun. Operable windows, shutters and fabric awnings make it possible for residents to control sunlight and fresh air within the building. Taking advantage of energy-efficient historic assets and responsibly retrofitting historic buildings can maximize their potential for energy conservation.

It is important, first of all, to use and maintain the existing energy-conserving features. Always consider replacing lost assets, such as shade trees and porches and introducing plantings and site features such as awnings, that aid in better energy management.

The first steps in retrofitting include the addition of adequate weatherstripping around window sashes and doors that prevent air leaks, and glazing that seals glass window panes. Once these repairs are made, storm windows and doors can be installed to provide a further barrier against the elements.

The installation of exterior storm windows is encouraged in the historic district for residential buildings. By keeping original windows and adding storm windows, owners can achieve energy savings equal to most new replacement windows and typically at a lower cost. Replacement windows have a finite life, requiring their own eventual replacement and increasing costs to the homeowner. Interior storm windows may also be an option but special care must be taken to ensure that moisture does not accumulate between the storm window and the original window, as this can cause damage to the wooden stools and surrounding area. Both exterior and interior storm windows must be fitted properly and be operable in order to receive their maximum benefit.



*Window awnings can assist in lowering energy costs during warmer months. Appropriate designs are shown above and below.*



*Porches are also appropriate locations for canvas awnings to reduce energy costs in warm months.*

To minimize the impact of exterior storm windows, narrow profile windows with a painted or baked enamel finish in a color compatible with the sash color are appropriate. The meeting rails of operable storm windows for double-hung windows shall align with the existing window division. Painted or stained wooden or aluminum storm doors with large glass panels that do not obscure the existing doors are also appropriate modifications to historic buildings.

The introduction, rehabilitation or replacement of mechanical or communication systems that include outside equipment, such as heating and air conditioning units, solar collectors, fuel tanks, gas meters, television antennas or satellite dishes, is to be planned with great care so that their location and installation will not damage or detract from the historic character of the building, site adjacent properties or the district as a whole.

Window air-conditioning units are acceptable, but shall be located as unobtrusively as possible. Modern installations shall always be located on secondary elevations, out of public view. Conformance with local building codes and utility company standards is required. New systems often dictate additional utility lines and poles. Care must be taken to avoid overpowering the streetscape with unsightly lines and poles. The use of underground cable might be considered as an alternative to such visual intrusion.

In most cases the HZC will normally require the following:

1. Retain and preserve the historic energy-conserving features and materials that contribute to the overall character of a building or site, including projecting front porches, louvered shutters, operable windows and transoms and large shade trees.
2. Protect and maintain historic energy-conserving features and materials. Enhance their thermal efficiency through appropriate, traditional practices, including the installation of weatherstripping and caulking, storm windows and doors, and, if appropriate, awnings and operable shutters.
3. Repair historic energy-conserving features.



*Appropriate storm door at 65 Pickwick Street.*



*This HVAC unit is effectively screened through lattice panels at 165 College Street.*

4. Replace historic energy-conserving features and materials in kind only when they are deteriorated beyond repair.

5. Install full-light storm doors constructed of wood or aluminum and wooden screen doors, if desired, so that they do not damage or obscure the existing door or frame. Select storm or screen doors with a painted, stained or baked-enamel finish in a color compatible with the existing door color. It is not appropriate to install storm doors with a bare metal finish.

6. Install narrow-profile exterior storm windows, if desired, so that they do not damage or obscure the window sash or frame. Select operable storm windows with meeting rails that align with the existing division of double-hung windows. Select storm windows with a painted or baked-enamel finish in a color compatible with the window sash color. It is not appropriate to install storm windows with a bare metal finish.

7. Replace missing or deteriorated wooden shutters with new shutters that are sized to fit the window opening and mounted to the window casing so they are operable or are fixed to appear operable.

8. Install fabric awnings over window, door and porch openings, if desired and where historically appropriate, so that historic features are not damaged or obscured.

9. Locate new utilities and mechanical equipment, such as meters, exposed pipes, wires and heating and air-conditioning units, in the most inconspicuous area, such as along the rear elevation or in a side yard location not visible from the street.

10. Mail boxes shall continue to be located on the front elevations of dwellings. Adding free-standing mail boxes at the sidewalk would not be appropriate for the district.



*Solar panels (above) and solar shingles (below) may be added to dwellings at their rear roof lines or side roofs not readily visible from the street.*



*Solar panels may also be added to rear yards as long as they are not readily visible from the primary street and are screened through landscaping or fencing.*

## Accessibility & Life Safety

---

When a historic building must undergo considerable revision due to a change in use or in order to meet the need for public access for people with disabilities, compliance with current standards for life safety and accessibility is required. The federal guidelines for the Americans with Disabilities Act of 1990 offer helpful flexibility in compliance for historic buildings. Property owners are encouraged to contact the Commission staff or members of the HZC for advice on the appropriate design and placement of accessibility ramps and other modifications.



*Avoid the construction of a prominent ramp on the front of a dwelling.*

Given the foundation height of most buildings in the Savannah Historic District, accessibility for persons in wheelchairs usually requires a ramp. The sensitive introduction of such a large, visible feature is clearly a challenge. Residential properties have the advantage of locating a ramp at a secondary entrance on an elevation out of street-view. Similarly, the addition of a fire exit or exterior fire stair requires sensitivity to the historic building. Changes such as the addition of a handrail for the front steps, can be handled more simply. Temporary and reversible options are favored over permanent and irreversible ones.

In most cases the HZC will normally require the following:

1. When considering a new use or change to a historic building, review all life safety code and accessibility requirements in deciding if the proposed change can be made without compromising the overall historic character of the historic building and its setting.
2. Accommodate life safety and accessibility requirements in ways that maintain and preserve the historic character of the building and its setting.
3. Introduce new or additional means of access, if needed, that are reversible and do not diminish the original design of a character-defining entrance or porch.
4. Locate access ramps as discreetly as possible to diminish their impact on the historic building and site, preferably on a secondary entrance. Keep their design simple and minimal in size and compatible with the scale, materials and details of the building.



*Consider the use of temporary or portable ramps rather than more permanent wood or metal ramps.*

5. Locate exterior fire stairs, fire doors or elevator additions on rear or inconspicuous side elevations. To diminish their impact, design these elements to be compatible with the architectural character, proportion, scale, materials and finish of the historic building. Elevators can sometimes be sensitively installed inside a house without affecting rooms, features, or details.

6. Relocate incompatible existing fire stairs, when possible, to inconspicuous locations, such as the building's rear elevation.



*Use landscaping or fencing to screen ramps on primary elevations.*



*Chair lifts are also a preferred method for accessing historic dwellings. This installation results only in the removal of a small section of porch railing which can be added back when the chair lift is no longer needed.*



---

## V. Residential New Construction

---

### Decks

---

Decks can be a compatible addition to a historic residence if they are carefully located, designed and constructed. As an alternative to a deck, residents may want to consider a covered porch or patio for a more compatible outdoor living area. To minimize the addition of a deck, it is very important that it be located inconspicuously and visually screened. As with other additions, it is important that the installation not damage significant features and materials of the building or site and that the deck be designed so that it is structurally self-supporting and could be removed in the future without harming the building. It is not recommended to try to directly imitate the building's architectural detail on such a contemporary addition as a deck. Appropriate designs can be achieved through the compatibility of materials, scale and color.

In most cases the HZC will normally require the following:

1. Introduce decks so that the overall character of the historic building and its site are not compromised.
2. Select inconspicuous locations for decks, usually on the rear or least visible elevation of the historic building. Screen decks from public view.
3. Construct decks so that the historic fabric of the building and its significant features and details are not removed, concealed, damaged or destroyed. Construct decks so that they may be removed in the future with no damage to the historic building.
4. Design decks and their elements, including rails and steps, to be compatible in material, color, proportion and scale with the historic building. Design details of decks shall be simple and not attempt to mimic historic detailing.
5. Screen the structural framing of decks with compatible foundation materials, such as skirtboards, lattice panels and dense evergreen foundation plantings.



*This deck is appropriately located at the rear of the dwelling.*



*Rear decks shall be built of materials to complement the historic dwelling without removal of original fabric.*

## Additions to Historic Dwellings

---

Most historic buildings have been altered and expanded to some extent over their many years of useful life. Many of these additions have become historic themselves, especially if constructed during the period of significance for the historic district. In fact, adding to the original shape and form of a building as needs for space and functions change may be essential to the continued usefulness of buildings within the Savannah Historic District. A successful addition must not visually overpower the original structure; concede its historic integrity; or destroy any significant features or materials, including historic plantings and site features. Additions shall not significantly alter the ratio of built area to green space of the building site or remove historic site features.

It is important that the original form of the building not be concealed or compromised by a new addition; consequently, an addition needs to be clearly differentiated from the original building. Additions that reflect the original style, as well as additions that introduce a compatible contemporary style, are both appropriate design approaches for additions in the historic district. A contemporary design achieves compatibility through massing, scale, form, and roof form in relation to the historic design, not through false mimicking. Designing an addition so that it can be removed in the future without further damage to the historic building prevents additional loss of historic materials.

In most cases the HZC will normally require the following:

1. Introduce additions, when necessary, so that the overall character of the historic building and its site are not compromised. It is not appropriate to introduce an addition if it will require the removal of a significant site feature or building element such as an original porch or a mature tree. Also, a historic addition, such as a rear wing, shall not be removed to accommodate a new addition.
2. Select inconspicuous locations for additions, usually on the rear or least visible elevation of the historic building.
3. Limit the scale and size of an addition so that it does not visually overpower or diminish the historic building or its site.



*Additions shall be sited at the rear or non-readily visible side elevations.*



*Additions shall be subordinate to the original dwelling and be differentiated through materials and detailing.*



4. Design additions so that the historic fabric of the building and its significant features and details are not concealed, damaged or destroyed.

5. Design additions to be compatible with the historic building in mass, roof form, materials, color and relationship of solid wall surfaces to windows and doors in the exterior wall; however, differentiate the addition from the historic building. It is not appropriate to attempt to make the addition appear to be a part of the original building by duplicating the form, style and details of the original building too closely.

6. Select a dominant exterior material for the addition that is compatible with that of the historic building. Contemporary substitute materials in place of traditional exterior materials on an addition to a historic building may be appropriate.

7. Align the foundation height with that of the historic building. Eave lines of additions shall be at or below the historic eave line. The latter demonstrates subordination to the historic building. Similarly, additions shall be inset from the corners of the historic building. It is not appropriate to design an addition whose height exceeds that of the historic building.

8. Construct additions so that if removed in the future, the form, integrity, and materials of the historic building are not damaged.

9. Protect archaeological resources and significant site features during and after construction by limiting site disturbances and changes in grade.



*This addition is recessed from the side wall of the original dwelling and is not visible from the street. Above is the front view and below is the addition from the rear view.*



*Utilization of unused attics and the addition of rear elevation dormers may also be an appropriate method to add additional living space to a dwelling.*

## New Construction of Residential Buildings

---

Construction of new buildings in the historic residential area of Savannah can contribute to its character and provide the opportunity to eliminate vacant lots. New buildings do not need to copy historic building designs, but they shall adhere to established neighborhood design principles. Contemporary designs are encouraged if they are compatible with the overall character of the historic district. The compatibility of proposed new construction is considered in terms of both the building and the building site.

Placement of a proposed building on its lot shall be consistent with the setback, spacing between buildings, orientation to the street and lot coverage characteristic of the historic district. For a streetscape, a consistent setback – the distance from the front wall of the building to the street – establishes a framework of order and coherence. Similarly, a regular pattern of spacing between buildings adds continuity to a streetscape. Throughout the historic district, the orientation of the main façade is consistently parallel to the street and the lot coverage – a measure of the density of developed land along each block front and for each lot – is fairly consistent. All of these siting characteristics are important to consider when introducing new buildings within the historic district. The physical and visual character of the site itself, including its topography and landscaping, can further relate the new construction to its surroundings and enhance its compatibility.

Compatibility of the overall design of a proposed building shall first be reviewed in terms of its scale, height, massing, proportion and roof form. By analyzing the buildings surrounding a proposed site in these terms, it is possible to discover how consistent and, therefore, significant each of these criteria is to the district character. Scale refers to the size of the construction units and their architectural details in relation to the size of a person. Like scale, height consistency is an important criterion in the district. Most blocks in the district contain a mixture of one- and two-story structures, and houses are built on raised foundations which contribute to the building height. The massing and proportion of buildings in the historic district range from simple rectangular boxes to complex interplays of offsets and projections. A variety of roof forms are also found throughout the historic district. It is important to consider the overall proportion of a front



*The Savannah Historic District has uniform side yard and front yard setbacks on many of the blocks. This spacing is important for any new primary dwellings.*

façade and roof form as viewed from the street for continuity. If nearby buildings are narrow two-story houses, their vertical proportion will be important to reiterate. Likewise, Bungalows with wide roofs and porches supported by tapered columns present a more horizontal proportion.

Building features, openings, details, materials and textures characteristic of the historic district provide additional criteria for evaluating the compatibility of proposed new construction. Front porches and chimneys are examples of historic building features. Particular attention shall be paid to the spacing, scale, placement, proportion and size of openings and the design of the windows and doors that fill them. Exterior trim and details, as well as the selection of materials and textures that clad the building exterior, give additional opportunities to relate proposed new construction to the historic district.

In most cases the HZC will normally require the following:

1. Site new construction to be compatible with nearby historic buildings that contribute to the overall character of the district in terms of setback, spacing between buildings, orientation to the street and lot coverage.
2. Design the new construction so that the overall visual and physical character of the building site, including its topography, mature plantings and historic site features, is retained.
3. Design new construction to be compatible with nearby historic buildings that contribute to the overall character of the district in terms of building scale, height, massing, proportion and roof form.
4. Design new construction to be compatible with nearby historic buildings that contribute to the overall character of the district in terms of building features, openings, details, materials and textures.
5. Design the spacing, scale, placement, proportion and size of window and door openings in proposed new construction to be compatible with nearby historic buildings that contribute to the overall district character.
6. Select windows and doors for proposed new construction to be compatible in design, materials, subdivision, proportion and detail with windows and



*One approach to infill residential construction in historic districts is to design a replica such as this new Bungalow dwelling above or this Queen Anne-influenced dwelling below.*



doors of nearby historic buildings that contribute to the overall character of the district.

7. Select materials, and their textures and finishes, for proposed new construction to be compatible with the materials, textures and finishes of nearby historic buildings that contribute to the overall character of the district. It may be appropriate to use contemporary substitute materials such as cementitious siding in place of traditional exterior materials.

8. Design new construction to be compatible with but discernible from historic buildings in the district. It is not appropriate to design new construction that attempts to duplicate historic buildings too closely in an effort to create a false historic appearance.

9. Parking for new construction shall be located on side or rear elevations and not in the front yards.

10. Protect archaeological resources and significant site features during and after construction.



*Another approach to infill residential construction in historic districts is to design buildings that are compatible in scale, roof form, materials, and window and door arrangement while having more contemporary details.*

---

## VI. Relocation and Demolition

---

### Relocation

---

Relocation of a building within the historic district shall be considered for only two reasons: one, as a last-resort alternative to demolition; and two, to execute the objectives of a revitalization plan that will place the building in a more compatible environment. Both of these are valid reasons to move a building, but it is important that such a decision be given careful consideration. Because relocation may result in a loss of integrity of setting and environment that can seriously compromise the significance of the relocated building, and because it is a complicated, time-consuming and expensive process, every aspect of the project shall be investigated, considered and evaluated before relocation is undertaken. Once the decision to relocate has been made, every effort shall be made to move the building intact as a single unit.

In most cases the HZC will normally require the following:

1. Relocate a building within the historic district only if the building is determined to be architecturally compatible with adjacent buildings according to the design guidelines for new construction and if the relocation will not damage or diminish the overall character of the historic district.
2. Site a relocated building within the historic district in accordance with the guidelines for siting new construction. Submit a proposed site plan for the new site to the Commission showing all site changes, including landscaping, driveways, parking areas and site lighting.
3. Prior to the relocation, record the historic structure on its original site through photographs and/or other documentation that records the original setting.
4. Prior to the relocation, work with contractors experienced in successfully moving historic structures to determine the structural stability of the building and to minimize any damage to the building before, during and after the move.
5. Select a route for the relocation that does not endanger significant features of the original site, the route through the historic district or the new site.



*Relocation of historic dwellings shall only be undertaken as an alternative to demolition or if moving the building is part of a broader revitalization plan.*

## Demolition

---

Demolition of a structure within the Savannah Historic District or of a designated historic property is an irreversible act that is strongly discouraged. Because historic assets can never be replaced, property owners shall always try to preserve the building and the site.

In reviewing a request to demolish a building in the downtown commercial district, the HZC will assess the effect of the proposed demolition on adjacent historic properties and on the overall character of the district. The HZC also seriously reviews the following considerations: the building's contribution to the historic character of the district; whether the building could be adapted to meet the owner's needs; whether the property could be sold to someone whose needs it would meet; whether the building could be relocated; and what use is being proposed for the site that will compensate for the loss of the structure. It is the responsibility of the property owner who is requesting a Certificate of Appropriateness for demolition to submit at the same time a proposed site plan once the building is gone.

In most cases the HZC will allow demolition only under the following circumstances:

1. If a building has lost its architectural and historical integrity and its removal will not adversely affect the district's historic character.
2. If the denial of the demolition will result in an unreasonable economic hardship on the applicant as determined by the HZC.
3. If the public safety and welfare requires the removal of a structure or building.
4. If the structural stability or deterioration of a property is demonstrated through a report by a structural engineer or architect. Such a report must clearly detail the property's physical condition, reasons why rehabilitation is not feasible, and cost estimates for future rehabilitation versus demolition. In addition to this report there will be a separate report which details future action on the site.
5. Any original storefront materials shall be salvaged as possible for use on any new commercial building on the site.



*Demolition shall always be the last option considered for historic buildings.*

**6.** The HZC does not review demolition applications within the Savannah National Register Historic District but property owners are encouraged to work with the HZC and other interested parties to salvage usable architectural features and materials.

**7.** In the residential district during the demolition, protect any large trees and other important landscape features from damage.

**8.** After demolition in the residential district, development of the property with a compatible new building or structure is recommended. If the site is to remain vacant for more than sixty days, clear the site of debris, re-seed it and maintain it in a manner consistent with other properties in the historic district.

---

## VII. Appendices

---

### Resources for Technical Assistance

---

#### **Local Resources**

Savannah Historic Zoning Commission  
140 Main Street  
Savannah, Tennessee 38372  
[www.townofSavannah.net](http://www.townofSavannah.net)

For information on the Savannah Historic Zoning Commission, Certificates of Appropriateness and technical assistance, contact Savannah's HZC at (731) 925-3300.

#### **State Resources**

State Historic Preservation Office  
Tennessee Historical Commission  
2941 Lebanon Road  
Nashville, TN 37243  
615-770-1087  
<http://tn.gov/environment/section/thc-tennessee-historical-commission>

#### **National Resources**

National Alliance of Preservation Commissions  
208 E. Plume Street  
Suite 327  
Norfolk, VA  
23510  
757-802-4141  
[director@napcommissions.org](mailto:director@napcommissions.org)  
<http://napcommissions.org/>

United States Department of the Interior  
National Park Service  
Post Office Box 37127  
Washington, D.C. 20013-7127  
[www.nps.gov/history/preservation.htm](http://www.nps.gov/history/preservation.htm)

Office of the Director: (202) 208-6843  
Office of Public Affairs: (202) 208-6843  
Preservation Assistance Division: (202) 343-9578

See the Secretary of the Interior's Guidelines for rehabilitating Historic Buildings at:  
[http://www.nps.gov/hps/tps/standguide/rehab/rehab\\_approach.htm](http://www.nps.gov/hps/tps/standguide/rehab/rehab_approach.htm)

NPS Preservation Briefs provide information on preserving, rehabilitating, and restoring buildings. These can be found at [www.nps.gov/tps/how-to-preserve/briefs.htm](http://www.nps.gov/tps/how-to-preserve/briefs.htm)



## Glossary of Architectural Terms

---

Architrave – The molded frame surrounding a door or window.

Arts and Crafts Movement (1900-1930) – A modern movement in domestic architecture which deliberately turned away from historic precedent for decoration and design. Ornamentation was modernized to remove most traces of its historic origins. Low pitched roofs with eave overhangs were favored.

Balustrade – A series of short pillars or turned uprights with a rail.

Bandboard – Any flat horizontal member that projects slightly from the surface of which it is a part; often used to mark a division in a wall.

Bargeboard – A wooden member, usually decorative, suspended from and following the slope of a gable roof.

Bay – (1) An opening or division along a wall of a structure, as a wall with a door and two windows is three bays wide; (2) A projection of a room, usually with windows and angled sides but sometimes rectangular.

Beveled Glass – A type of decorative glass on which the edges of each pane are beveled or cut to an angle of less than ninety degrees.

Board-and-Batten – Vertical exterior siding with the joints between the siding (boards) covered with narrow strips (battens). The battens are used to conceal the gaps between the siding boards.

Bracket – Projecting support member found under eaves or other overhangs; may be plain or decorated.

Brick Header – Bricks laid with their ends towards the face of a wall.

Bungalow (1890-1940) – An architectural style characterized by small size, overall simplicity, broad gables, dormer windows, porches with large square piers and exposed structural members or stickwork.

Casement Window – A window sash that opens on hinges fixed to its vertical edge.

Casing – The finished visible framework around a door or window.

Chimney Pot – A terra cotta, brick or metal pipe that is placed on top of a chimney as a means of increasing the draft; often decoratively treated.

Clapboard – A narrow board, usually thicker at one edge than the other, used for siding.

Colonial Revival (1870-1950) – An architectural style characterized by a balanced façade; use of decorative door crowns and pediments, sidelights, fan lights and porticos to emphasize the front entrance; double-hung windows with multiple panes in one or both sashes; and frequent use of string courses on decorative cornices.

Corbelling – A series of projections, each stepped out further than the one below it; most often found on masonry walls and chimney stacks.

Corner Board – A board that is used as a trim on the exterior corner of a wood frame structure and against which the ends of the siding are fitted.

Cornice – The exterior trim of a structure at the meeting of the roof and wall, usually consisting of bed molding, soffits, fascia and crown molding.

Craftsman Style (1905-1930) – An architectural style featuring low pitched gable roofs with wide, unenclosed eave overhang, roof rafters usually exposed, decorative beams or braces commonly added under the gables, porches with roof supported by tapered square columns and columns frequently extending to the ground level.

Crown Molding – The crowning and finished molding, most often located in the area of transition between wall and ceiling or on the extreme top edge of an exterior wall.

Dentil – A row of small blocks at the base of a classical cornice, resembling a row of evenly spaced teeth.

Dormer – A vertical window projecting from the slope of the roof, usually provided with its own roof.

Double Hung Window – A type window with upper and lower sashes in vertical grooves, one in front of the other, which are moveable by means of sash cords and weights.

Drop Siding – A type of cladding characterized by overlapping boards with either tongue and groove or rabbeted top and bottom edges.

Eave – The part of the sloping roof that projects beyond a wall.

Elevation – The external faces of a building; also a drawing to show any one face of a building.

Embossed – Carved or raised in relief.

Etched Glass – Glass whose surface has been cut away with a strong acid or by abrasive action into a decorative pattern.

Façade – The front face of a building.

Fascia – A flat board used to cover the ends of roof rafters.

Fenestration – The arrangement of windows and other exterior openings on a building.

Flashing – Pieces of non-corrosive metal installed at junctions between roofs and walls, around chimneys and around other protrusions through the roof.

Flush Siding – Wooden siding which lies in a single plane. This was commonly applied in a horizontal direction except when applied vertically to accent an architectural feature.

Foursquare – Two story, box-shaped house style prevalent during the early twentieth century.

Friable – Easily crumbled or pulverized.

Frieze – The middle division of an entablature, between the architecture and cornice; usually decorated but may be plain.

Gable – The triangular end of exterior wall in a building with a ridged roof.

Gable Roof – A sloping (ridged) roof that terminates at one or both ends in a gable.

Gingerbread – Thin, curvilinear ornament produced with machine-powered saws.

Grapevine Joint – An archaic mortar joint similar to a concave joint with a groove scribed into the center of it.

Hardboard – A very dense fiberboard usually having one smooth face.

Hipped Roof – A roof formed by four pitched roof surfaces.

Jalousie – The craft of connecting members together through the use of various types of joints; used extensively in trim work and in cabinet work.

Knee Bracket – A diagonal member for bracing the angle between two joined members, as a stud or column and a joist or rafter, being joined to each partway along its length.

Lintel – A horizontal beam bridging an opening.

Masonry – Work constructed by a mason using stone, brick, concrete blocks, tile or similar materials.

Meeting Rail – (in a double hung window) The rail of each sash that meets a rail of the other sash when the window is closed.

Metal Buildings – Prefabricated structures faced in sheet metal.

Mission Tiles – A red roof material made of fired clay.

Molding – A continuous decorative band; serves as an ornamental device on both the interior and exterior of a building or structure; also often serves the function of obscuring the joint formed when two surfaces meet.

Mullion – A vertical support dividing a window or other opening into two or more parts, or that separates two windows.

Muntin – A thin strip of wood or steel used for holding panes of glass within a window sash.

Neoclassical (1900-1940) – An architectural style characterized by a two-story pedimented portico or porch supported by colossal columns, a centrally located doorway and symmetrically placed windows.

Palladian Window – A window with three openings with a large arched central light flanked by rectangular sidelights.

Parapet - A low wall rising from the roofline of a building façade.

Parging – A technique of applying a cement-type coating to a masonry surface.

Pediment – A triangular section framed by horizontal molding on its base and two sloping moldings on each of its sides; used as a crowning element for doors, windows and niches.

Pendant – A hanging ornament; usually found projecting from the bottom of a construction member such as a newel in a staircase, the bottom of a bargeboard or the underside of a wall overhang.

Pier – Vertical supporting member that is part of the foundation.

Pitch – The degree of slope on a roof.

Portico – A covered walk or porch supported by columns or pillars.

Prairie Style (1900-1920) – An architectural style characterized by its overall horizontal appearance which is accomplished through the use of bands of casement windows, long terraces or balconies, flanking wings, low-pitched roofs with wide overhangs and darkly colored strips or bands on exterior walls.

Quarter Round – A small molding that has the cross section of a quarter circle.

Queen Anne (1800-1910) – An architectural style characterized by irregularity of plan and massing, variety of color and texture, variety of window treatment, multiple steep roofs, porches with decorative gables, frequent use of bay windows, chimneys with corbelling and wall surfaces that vary in texture and material use.

Rabbet – A joint formed by cutting a rectangular groove in one member to receive the end of another member.

Railing – (1) A fence-like barrier composed of one or more horizontal rails supported by widely spaced uprights; balustrade; (2) Bannister; (3) Rails, collectively.

Reconstruction – The act of reproducing by new construction the exact form and detail of a vanished building, structure or object as it appeared at a specific period of time.

Reglaze – To remove and replace deteriorated putty with new putty between the glass and the wood on a window, to create a weather-tight seal.

Rehabilitation – The act or process of returning a property to a state of utility through repair or alteration, which makes possible efficient contemporary use while preserving those portions or features of the property which are significant to its historical, architectural and cultural values.

Renovation – The restoration to a former better state by cleaning, repairing or rebuilding.

Repointing – Removing old mortar and replacing it with new mortar.

Restoration – The act or process of accurately recovering the form and details of a property and its settings as it appeared at a particular period of time, by means of the removal of later work or by the replacement of missing earlier work.

Ridge – The horizontal line formed when two roof surfaces meet.

Riser – Each of the vertical boards closing in the spaces between the treads of stairways.

Sandblast – An abrasive method of cleaning bricks, masonry or wood that involves directing high-powered jets of sand against a surface, causing damage to wood and brick.

Scale – The size of the construction units, architectural elements and details in relation to the size of man.

Setback – The distance from the front wall of the building to the property line or the street.

Shed Dormer – A dormer with a roof consisting of one inclined plane.

Sidelight – A fixed sash located beside a door or window, often found in pairs.

Sill – The horizontal water-shedding member at the bottom of a door or window.

Sillplate – The horizontal member that rests on the foundation and forms the lowest part of the frame of a structure.

Solarium – A glass-enclosed porch or room.

Spacing – The distance between adjacent buildings.

Stack – A number of flues embodied in one structure rising above a roof.

Spandrel – The sometimes ornamental space between the right or left exterior curve of an arch and an enclosing right angle.

Stucco – An exterior wall covering consisting of a mixture of Portland cement, sand, lime and water.

Surround – The frame around a door or window, sometimes molded.

Terra Cotta – A fine-grained fired clay product used on the exterior of buildings; may be glazed or unglazed, molded or carved; usually brownish red in color, but may also be found in tints of gray, white and bronze.

Tongue-and-Groove – A joint made by a tongue on one edge of a board fitting into a corresponding groove on the edge of another board.

Topography – The physical and natural characteristics of a site, especially referring to the changing contours of ground level.

Topping – The indiscriminate cutting back of tree branches to stubs or lateral branches that are not large enough to assume the terminal role.

Transom – A small window or series of panes above a door or above a casement or double-hung window.

Triple A Roof – A colloquial term used to describe the false center gable often found on late nineteenth- and twentieth-century domestic roofs. Also used as a name for a vernacular house containing such a roof configuration; term is derived from the three “A” shaped gables: side, front and side.

Tudor (1890-1940) – An architectural style characterized by steeply pitched and gable roofs, gabled entranceway, multi-paned narrow windows, tall chimneys (often with chimney pots), masonry construction and decorative half-timbering in many cases.

Turret – A small and somewhat slender tower; often located at the corner of a building.

Valley Flashing – Copper, galvanized sheet metal or aluminum strips placed along the depressed angle formed at the meeting point of two roof slopes.

Veneer – A decorative layer of brick, wood or other material used to cover inferior structural material, thereby giving an improved appearance at a low cost.

Veranda – A roofed open gallery attached to the exterior of a building.

Vernacular – In architecture, as in a language, the non-academic local expressions of particular region.

Victorian Style – A loose term for various styles of architecture, furniture or clothes popular during the reign of Queen Victoria (1837-1901); architectural styles are primarily characterized by fanciful wooden ornamentation or “gingerbread.”

Weatherboards – Exterior wood siding consisting of overlapping boards usually thicker at one edge than the other.

Wood Shakes – Hand-cut wood shingles. Shakes can be distinguished from shingles in that shakes are not tapered and usually have more irregular surfaces. Their length varies from twelve inches to over three feet.

## Normal Maintenance Items

---

A Certificate of Appropriateness is not required for normal maintenance items which make no irreversible or significant change to the building or site. Normal maintenance includes the following:

- ❑ Maintaining the public-right-of-way through repairing sidewalks; marking pavement; resurfacing streets; maintaining utility poles, wires, traffic signals and street lights; repairing under-ground utilities; and maintaining the landscaping.
- ❑ Minor landscaping, including vegetable and flower gardens, shrubbery and rear yard trees. Pruning (not topping) trees and shrubbery; removal of trees less than four inches in diameter at two feet above the ground.
- ❑ Repairs to walks, patios, fences and driveways when replacement materials match the original or existing materials in detail, dimension and color.
- ❑ Removal of cinder block walks or steps; removal of railroad ties or landscape timbers around planting beds.
- ❑ Repair or removal of signs. Erection of temporary signs (real estate, political).
- ❑ Installation of house numbers, mailboxes and flag brackets.
- ❑ Removal of aluminum awnings; aluminum storm windows and doors; metal storage buildings; satellite dishes; underground oil tanks.
- ❑ Replacement of small amounts of missing or deteriorated siding, trim, roof shingles or porch flooring when the replacement materials match the original or existing in material, color and detail. (For siding, roofing and porch flooring, approximately twenty square feet or less will be considered normal maintenance.)
- ❑ Repainting siding and trim in the same colors.
- ❑ Caulking and weatherstripping; replacing window glass.
- ❑ Repairs to exterior lighting fixtures when replacement materials match the original or existing materials in detail.

## Minor Work Items

---

Upon receipt of a completed application, staff may issue a Certificate of Appropriateness (COA) for minor works that are consistent with the Savannah Design Principles and Guidelines, on behalf of the Commission. Where any uncertainty exists as to whether a COA *shall* be issued for minor work, staff shall refer the matter to the Commission. Minor works include the following:

- ❑ Removal of asbestos, aluminum, vinyl or other artificial siding not belonging to the original structure.
- ❑ Replacement of missing architectural details, provided that at least one of the following conditions are met: (1) at least one example of the detail to be replaced exists on the house, or (2) physical or documentary evidence exists which illustrates or describes the missing detail or details.
- ❑ Removal of dead, diseased or dangerous trees.
- ❑ Removal of accessory buildings which are not architecturally or historically significant.
- ❑ Removal of metal flues, gutters and downspouts.
- ❑ Repair or replacement of exposed foundation walls, including installation of vents.

- ❑ Repair or replacement of asphalt or fiberglass shingle roofs or other roof coverings where there is no change in material.
- ❑ Repair or replacement of flat roofs.
- ❑ Reconstruction or repair of fences of wood, stone, brick or cast iron under four feet high.
- ❑ Replacement of patios and decks that are not visible from the street.
- ❑ Installation or replacement of storm windows and doors, which are finished to match the color of the building's trim.
- ❑ Installation of mechanical equipment, such as heating and air conditioning units, not visible from the street.
- ❑ Review of material samples and dimensions for projects which have received approval in concept or a COA from the Commission.
- ❑ Renewal of expired COAs where no change to approved plans is being proposed and where there is no change in the circumstances under which the COA was granted.